

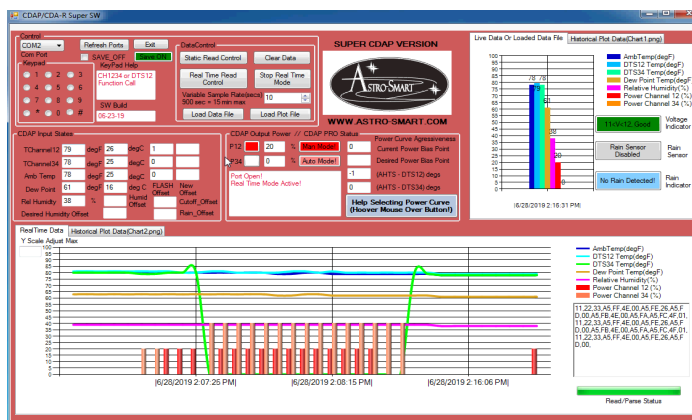

User's Manual Computerized Dew Annihilator (CDA-R Family Models)



Copyright Jan 2020

User's Manual
for the
Astro-Smart
Computerized Dew Annihilator Family Controllers

Contents

A. Overview 2

B. Features 5

C. Typical System Configurations..... 7

D. Contents of Box..... 12

E. Input / Output Power Specifications 12

F. CDA-Family Front Panel And Connector Diagram 14

G. Basic Functionality Auto Mode Vs. Manual Mode20

H. CDAR Setup and BootUp: Default 22

I. Standard WebGUI PC Dew Control Remote User Interface Summary 23

J. Summary WebGUI Entry Commands (System Control).....39

K. Default Operation (Automated Dew Control)..... 43

L. Manual Operation (Apply Heat As Desired On Channels) 47

M. External Temperature Sensor Hints: 51

N. Accessories..... 53

O. Warranty, Policies, Copyright Notice:..... 59



Providing the Astronomical Community with Premier Products and Services

Astro-smart.com

Copyright © 2010-2049, All rights reserved

Jan 2020

A. Overview

The [**CDA family controller s**](#) can be setup with your telescope **As-is** placed in automatic mode for trouble-free operation or can be controlled standalone or monitored and controlled by computer with the com port interface.

Astro-Smart is the innovator of this elegant *automatic solution to your dew problem*. The **Computerized Dew Annihilator** family is one to the most advanced dew controller s made available to the amateur or professional Astronomer and at a price comparable by no other system on the market. **The Computerized Dew Annihilator** family is designed to be used with any make or model of telescope which has more features than any other dew control system being offered at a fraction of the cost. Whether you have a refractor, newtonian, schmidt-cassegrain, or a ritchey-chretien, the **Computerized Dew Annihilator** family will solve your dew problems automatically while informing you every step of the way. It's like having a hired dew specialist posted at your telescope 24/7.

The **Computerized Dew Annihilator family** systems incorporates a common four port heater capability controlling multiple channels using multiple channel temperature sensors . Looking at the figure 1 below, one sensor(DTS-12) may be used for the main imaging telescopes corrector plate for dew control while the second(DTS-34)is used for another mounted imaging scope, guider or finder scope or your eyepieces. Each monitored sensor channel location is then paired with its associated output heat strap channel for dew control. For instance, DTS12 sensor would be placed on the optical corrector and the heat strap would go around the optical interface tube for instance CH1 or CH2 or both.

In the following pictures you can see **Model SM-RS-CDA-R, OC-RS-CDA-R, SM-CDA-R, RS-CDA-R, RC-CDA-R and CDA-R-** systems. **All CDA family controllers** come with the following features.

1. Common 4 heat channels and coupled temperature sensor channels(CH1/CH2<--->DTS-12)(CH3/CH4<--->DTS-34).



Providing the Astronomical Community with Premier Products and Services

Astro-smart.com

Copyright © 2010-2049, All rights reserved

Jan 2020

2. Center AHS channel is for ambient temperature and humidity monitoring normally placed against the optical tube of your main imaging telescope.

3. PWM LED indicators to show the dew control PWM rate and a low voltage cutoff circuit with LED indicator for power supplies for battery source protection.

The integrated approach adds these base features from the **CDA family** with other features with your dew controller to perform integrated tasks.

The new **RC-CDA-R system shown below** adds additional features over the CDA-R such as a low voltage cutoff circuit protection with LED cutoff indicators for power supplies using battery sources and a fan cool down feature for primary mirror RC's. As an example in this configuration as shown above, DTS sensors and heater channels 1/2 would be attached to secondary while DTS sensors and heat channels 3/4 would be attached to the primary of your RC and or SCT. With the FAN control offering for the primary, any time the temperature of primary exceeds ambient, the FAN would come on and cool the primary and turn off primary heat.

The new **RS-CDA-R** has the features of the **CDA-R** plus rain sensor detection, alarm and output relay control capabilities to close and observatory or operate an AC or DC appliance.

The new **SM-CDA-R** system has all the features of the **CDA-R** plus a sky quality meter (**SQM**) system. This informs the user of sky conditions and a intelligent computer software GUI consultant informing the user if the sky conditions are suitable for imaging, visual, technical work or too just cloudy and or presence of non-steady sky's due to too much atmospheric fluctuation and reflectivity. The **SQM** features of the **SM-CDA-R** include a graphical reporting system on the software GUI which graphically maps **NELM(Naked Eye Limiting Magnitude)** and **MPSAS (Magnitude Per Square Arc Sec)** over a programmable measurement scale as low as 1 sample every 3 seconds. The **SM-RS-CDA-R** includes all features the **SM-CDA-R** has plus rain sensor detection and power cut off features as included in all **CDA family** series controllers. The **OC-RS-CDA-R** has a relay output for observatory control plus rain sensor detection added to the integrated dew controller.



Providing the Astronomical Community with Premier Products and Services

Astro-smart.com

Copyright © 2010-2049, All rights reserved

Jan 2020

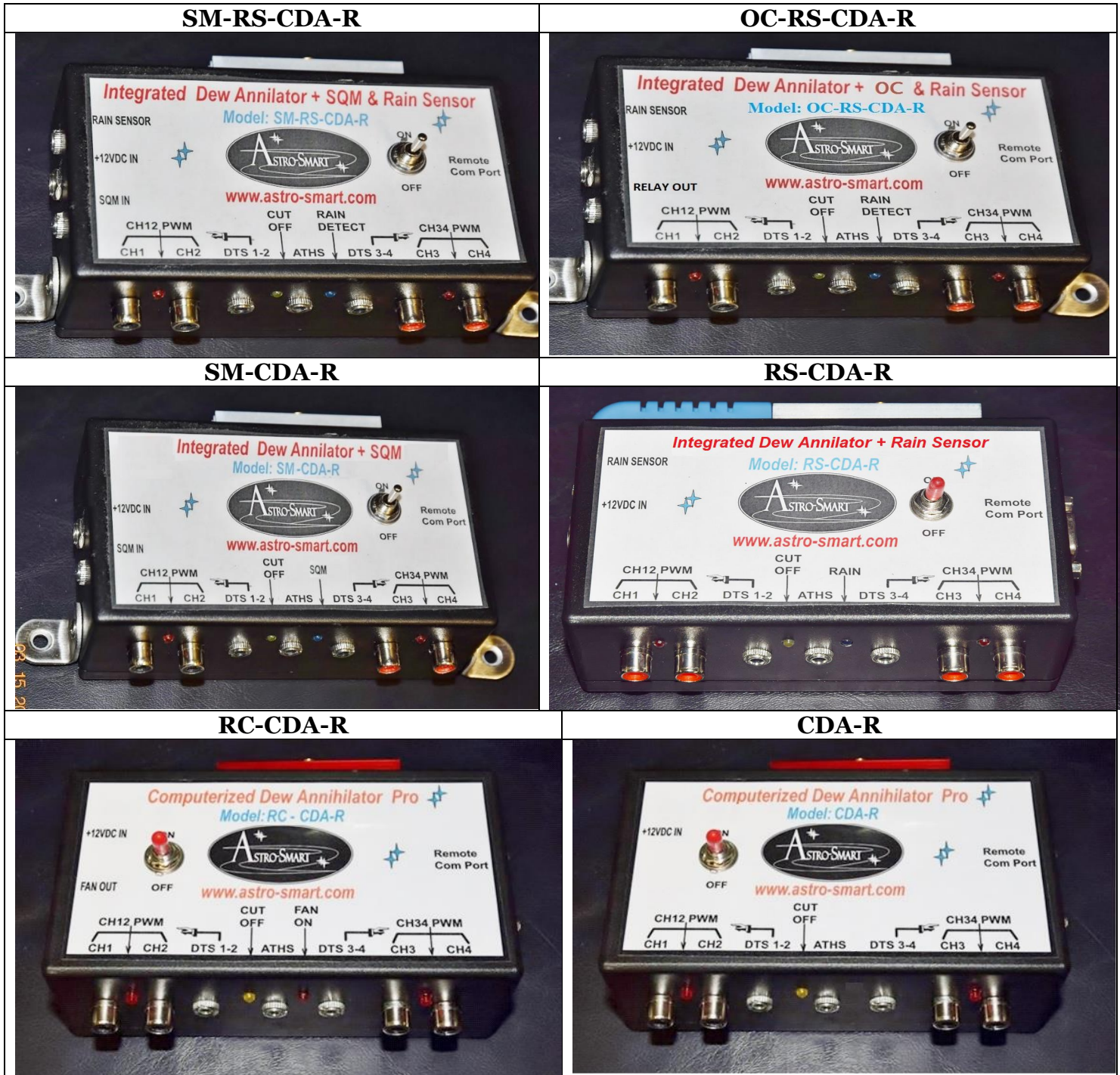

Shown below is the product pictures and feature map matrix.



Providing the Astronomical Community with
Premier Products and Services

Astro-smart.com

Copyright © 2010-2049, All rights reserved

Jan 2020

B. Features

Since, the inception of this unique product at Astro-Smart, the **Computerized Dew Annihilator** was many years in the making, over long periods in astronomy using existing products on the market to control dew, identifying their weaknesses and limitations making the product you see before you. Features such as Patent Pending Heat Distribution which minimizes heat currents on optics during imaging, Humidity Measurement, Dew point and Differential Temperature Alarms with automated decision making on Dew Control, Updateable Firmware, Computer Control, Intelligent Software Computer GUI interface to name a few. The family of **CDA controller s** are finally here!!! The Astro-Smart **Computerized Dew Annihilator are Observatory Class Dew Removal Systems** designed to be user friendly, serviceable, elegant and reliable and include the model features listed below in the following table:



Providing the Astronomical Community with Premier Products and Services

Astro-smart.com

Copyright © 2010-2049, All rights reserved

Jan 2020

Features	SM-RS-CDA-R	OC-RS-CDA-R	SM-CDA-R	RS-CDA-R	RC-CDA-R	CDA-R
1 Integrated Sky Quality Meter Measurement And Control (Accurate to 0.1 Mag / Arc Second Squared) MPSAS, NELM)	X		X			
2 Integrated Observatory Control Upto 10 Amps, 120V. Typical Use 12/24/32 V, 10 Amp.		X		X		
3 Integrated Rain Sensor Support With Observatory Safety Control	X	X				
4 12 VDC Fan Control Output For RC Primary Mirror Cool Down. Automatic Or Manual Control And LED Indicator. Fan Turns On When Primary Temp > Ambient.					X	
5 LED Flash Indicators For Heat PWM Output Ports.	X	X	X	X	X	X
6 Low Voltage Cut-OFF Circuit And LED Indicator.. Cutoff at 10.5-11VDC Programmable.	X	X	X			
7 Full Computerized Automatic Or Manual Operated Dew Control Solution.	X	X	X	X	X	X
8 4 Automated or Manual Output Port Heat Channels User Control Capable of 120 Watts(12V, 10Amps). Works with Astro-Smart RCA type heat strap and other compatible straps such as Astro-Zap, Kendrick, etc.	X	X	X	X	X	X
9 Over Current, Reverse Current and Over Voltage Protection Design with Switchable ON/OFF Power.	X	X	X	X	X	X
10 2 Differential Temperature and 1 Ambient Temp/Humidity Measurement and Control. Accuracy 0.5degs @ 25 deg C.	X	X	X	X	X	X
11 Automated Or Manual Dew Point and Temperature Variance set point for Dew Control. 1-10 degs.	X	X	X	X	X	X
12 Variable Power Control Duty Cycle 0-100%, 300 Hz max. Patented Asto-Smart Wave Cancellation Method And Pulse Width Modulation(PWM) for Efficient Heat Output Tailored for Extreme Dew Removal, Reduced Wave Interference with CCD Imaging and Conservation of Power Drawl.	X	X	X	X	X	X
13 Audible Alarms For Dew Point Approaching(DWP) and Differential Delta Monitoring.	X	X	X	X	X	X
14 User Selectable Power Curve Algorithms and Bias Offset Control	X	X	X	X	X	X
15 User Settable and Flash Storable Setting Thresholds For Various Sensor Inputs	X	X	X	X	X	X
16 Dual Fahrenheit or Celsius Temperature Display Feature.	X	X	X	X	X	X
17 Updatable Firmware and Standalone Software OS GUI Interface.	X	X	X	X	X	X
18 Long Distance Remote Control Interface To Observatory including Windows Software Interface Via Remote Computer. The CDAP-PRO interface supports Serial, USB, Ethernet and Wireless(New Feature!) backhauls.	X	X	X	X	X	X
19 Automated System Data Logger Storage, Retrieval and Plot Comparison Capability.	X	X	X	X	X	X
20 High quality design employs multi-layer PCB form factor and only the best quality components conformal coatings for outdoor use.	X	X	X	X	X	X
21 Void of RFI(Radio Frequency Interference) protected to enhance Astro-Imaging .	X	X	X	X	X	X
22 Worry Free Warranty Program For Life Of Product Sale.	X	X	X	X	X	X
23 Price point set below development cost for such a system while providing more features.	X	X	X	X	X	X



Providing the Astronomical Community with Premier Products and Services

Astro-smart.com

Copyright © 2010-2049, All rights reserved

Jan 2020

C. Typical System Configurations

Typical configurations for the [CDA Family Controllers](#) are shown below.

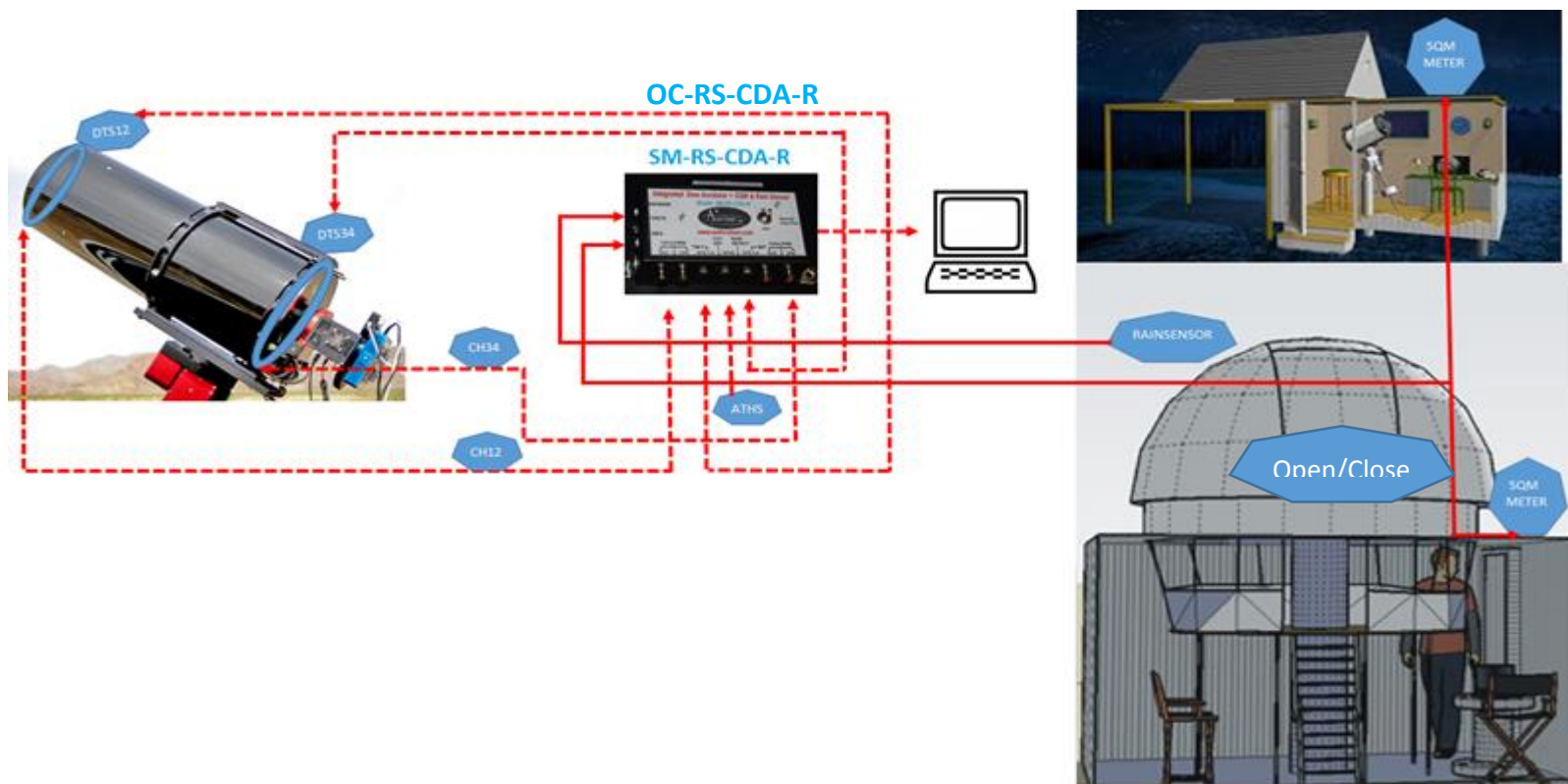



Providing the Astronomical Community with Premier Products and Services

Astro-smart.com

Copyright © 2010-2049, All rights reserved

Jan 2020

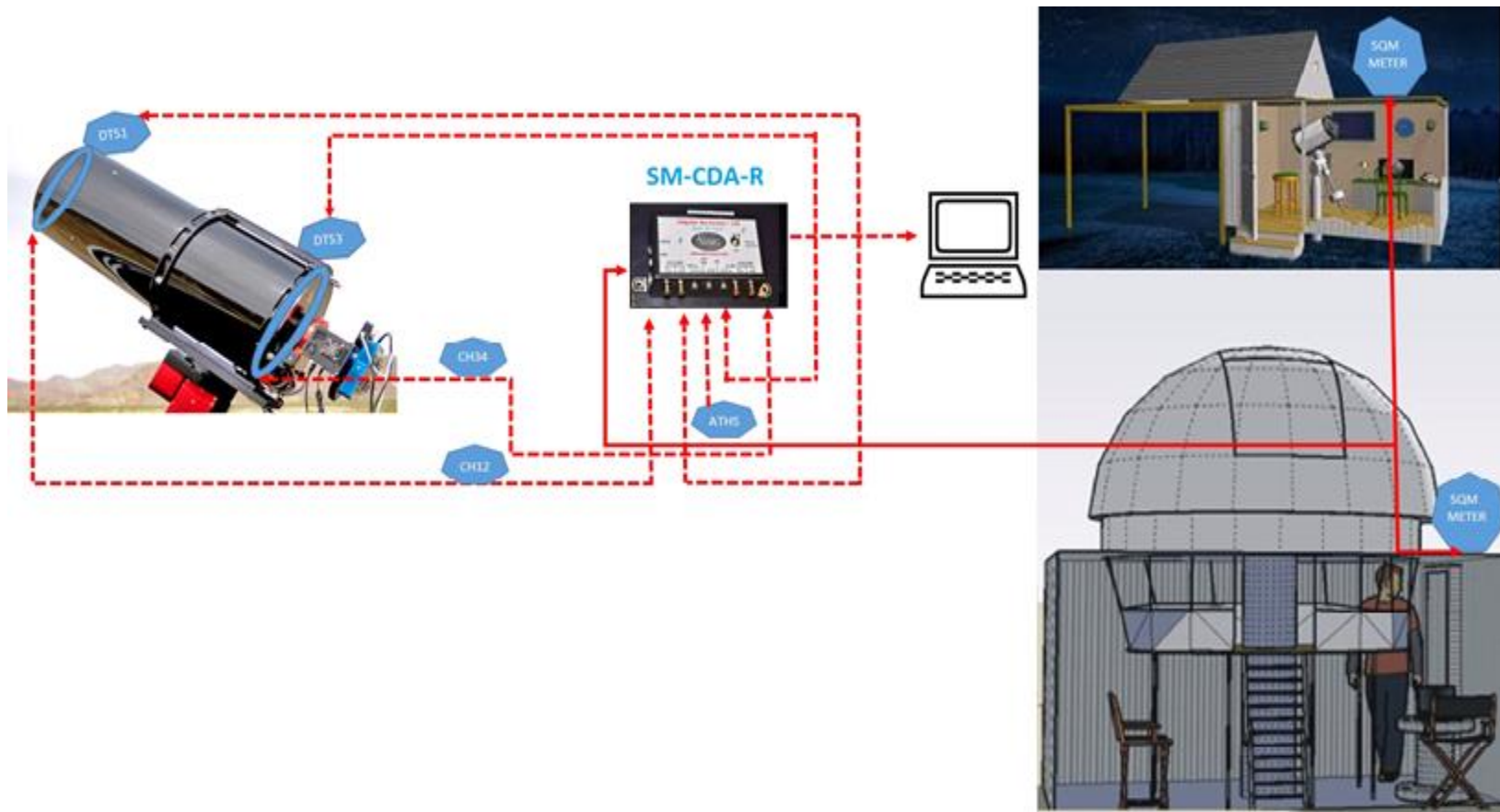



Providing the Astronomical Community with Premier Products and Services

Astro-smart.com

Copyright © 2010-2049, All rights reserved

Jan 2020

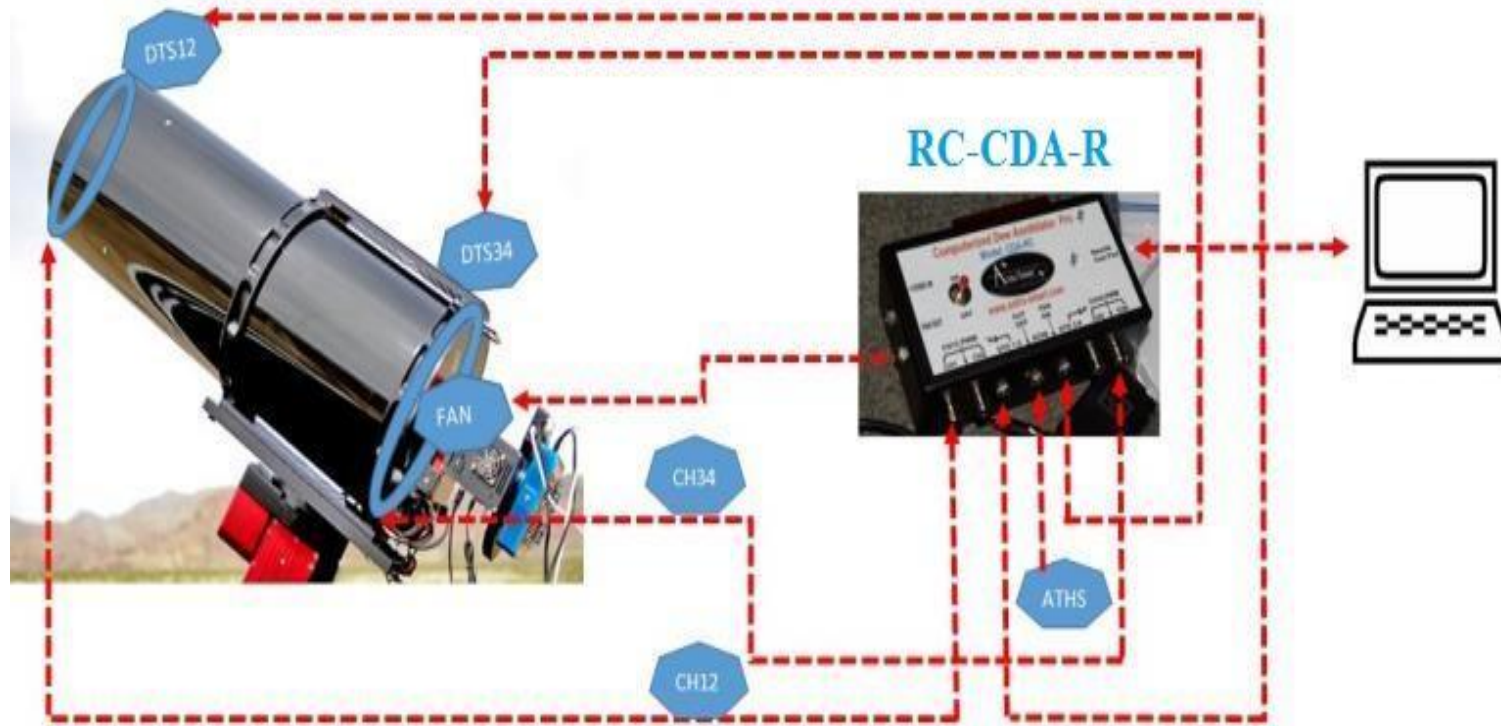



Providing the Astronomical Community with Premier Products and Services

Astro-smart.com

Copyright © 2010-2049, All rights reserved

Jan 2020

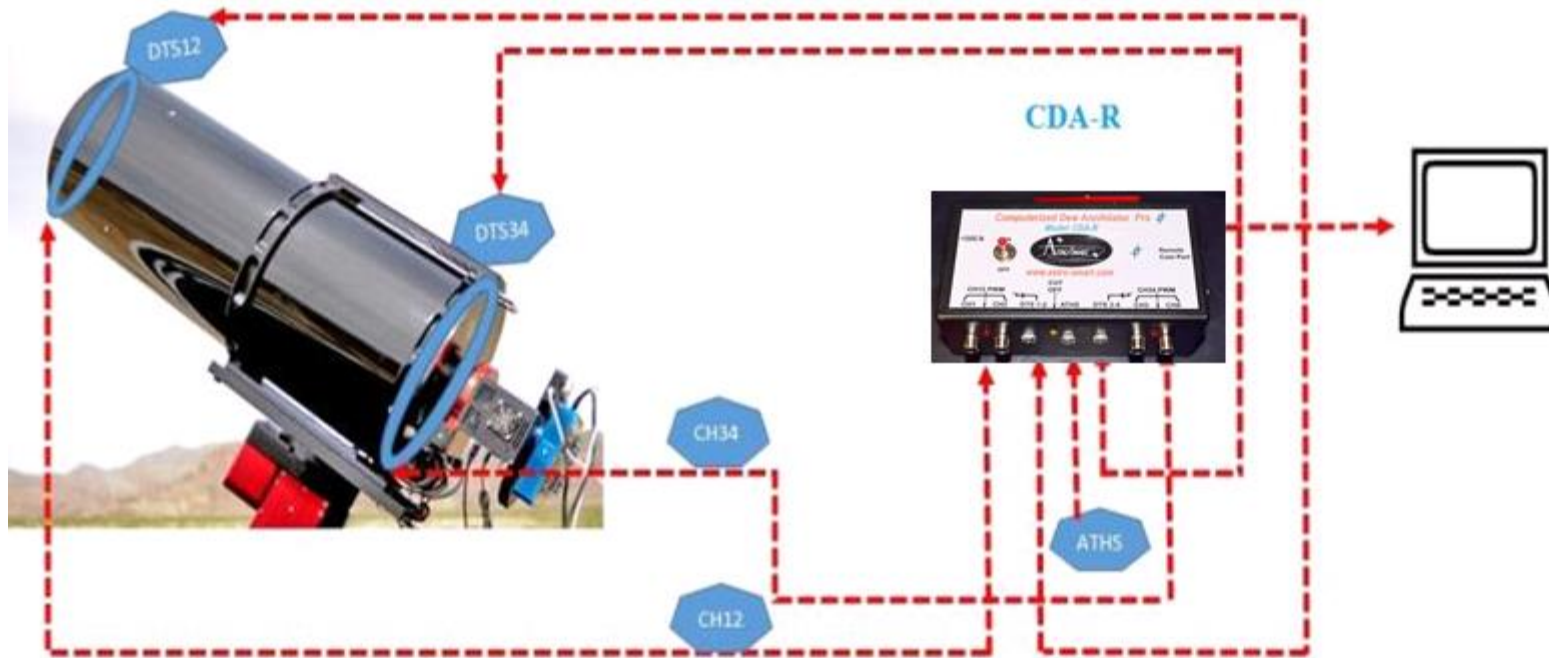



Providing the Astronomical Community with Premier Products and Services

Astro-smart.com

Copyright © 2010-2049, All rights reserved

Jan 2020

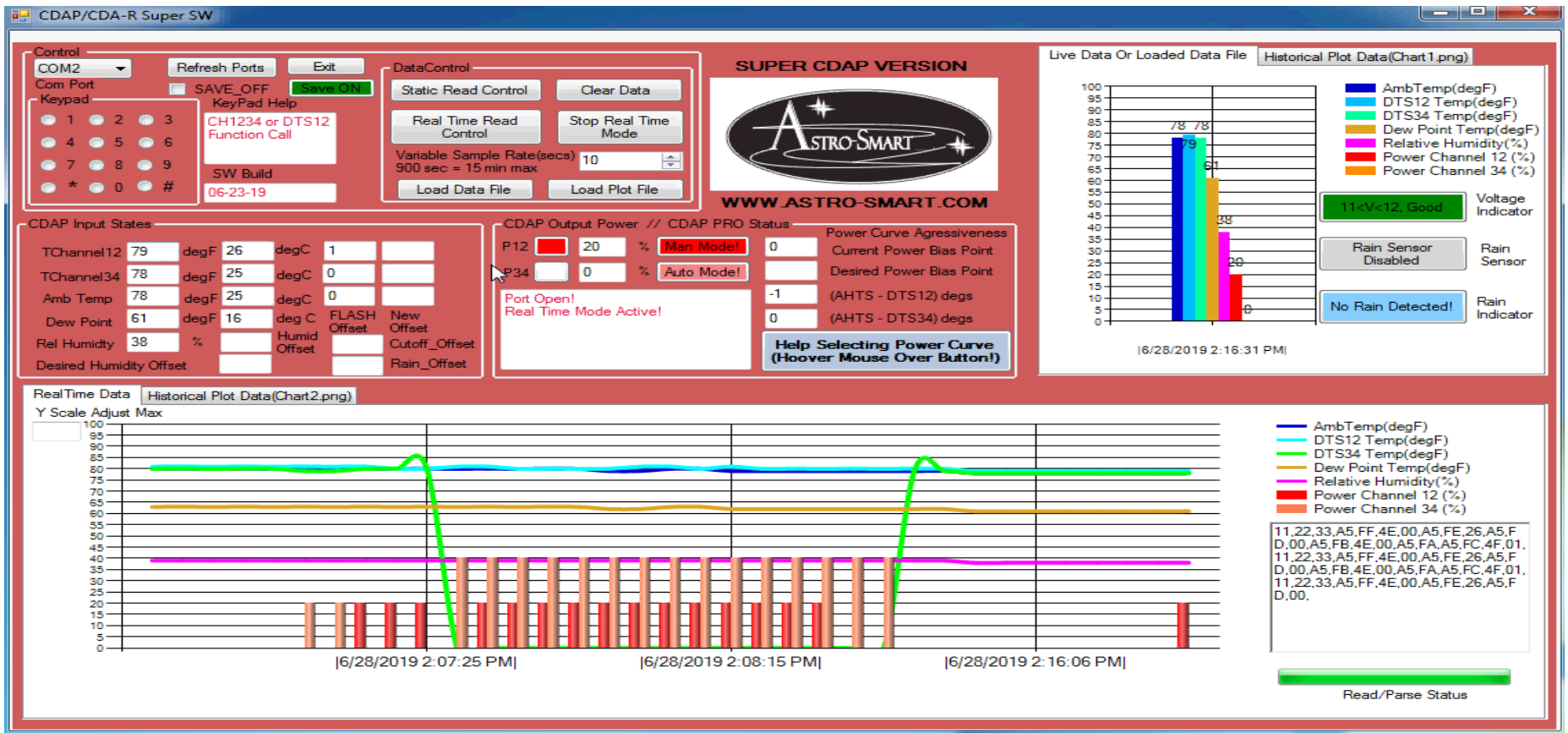

User GUI interface shown above. Details for use described in later chapters. For more information on operation of these products, see the user manual links and video tutorial links on the web site support page including video tutorial links.



Providing the Astronomical Community with Premier Products and Services

Astro-smart.com

Copyright © 2010-2049, All rights reserved

Jan 2020

D. Contents of Box

The package contents are shown below with choice of:

SM-RS-CDA-R, OC-RS-CDA-R, SM-CDA-R, RS-CDA-R, RC-CDA-R or CDA-R.

- 1. CDA-R Family Controller with Dew Point, Humidity, Ambient temperature sensor and Remote Capability.*
- 2. One Ambient/Humidity Temperature Sensor Probe.*
- 3. One USB interface Assembly Cable For Long Distance Remote Control Operation.*
- 4. One CD with user manual, CDA-R PC Remote Software Platform, Videos, Tutorials and Astro-Smart Sales Brochures*
- 5. Cigarette 12VDC fused power adapter harness.*

Other Accessories Show Below in Section N:

E. Input / Output Power Specifications

The **CDA-R FAMILY controller** requires the following:

- At a minimum of 12 Volts DC at 3.3 amps a 2.5mm DC power connector on your AC/DC supply. Based on the 4 channel configuration, the **CDA-R FAMILY controller** is rated at 5 Amps per duplexed channel or 10 Amps total. Ie. Ch1-2 5 Amp max + Ch3-4 5 Amp max for a total of 10 Amps at 12 VDC which gives a variety of heat strap configurations possible. A power supply rated at 12 VDC and 10 Amps rms is the ideal configuration which astro-smart recommends and provides as a purchase option.

Note: This current drawn through the **CDA-R FAMILY controller** is dependent on the resistance of each dew strap being used with the **CDA-R FAMILY controller**. The total current for all the dew straps must not exceed the power supply current rating.



Providing the Astronomical Community with Premier Products and Services

Astro-smart.com

Copyright © 2010-2049, All rights reserved

Jan 2020

The total resistance of all the dew straps used with the iDDHM must follow this equation for SAFE operation:

$$\frac{\text{Current Rating of Power Supply}}{\text{Voltage output of Power Supply}} = \frac{1}{R_{\text{strap 1}}} + \frac{1}{R_{\text{strap 2}}} + \frac{1}{R_{\text{strap 3}}} + \frac{1}{R_{\text{strap 4}}}$$

Astro-Smart assumes no responsibility if this warning is not heeded.

- Center positive voltage, sleeve ground, see Figure 1.

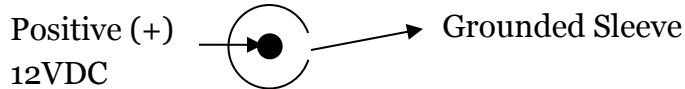

Figure 1 DC power plug

- Uses dew straps manufactured by other astronomical vendors.
- **Note:** Astro-Smart recommends you buy our certified tested power supplies for this product. Users can buy and connect their own power supplies to this product, but they do so at their own risk.



Providing the Astronomical Community with
Premier Products and Services

Astro-smart.com

Copyright © 2010-2049, All rights reserved

Jan 2020

F. CDA-Family Front Panel And Connector Diagram

➤ **Computerized Dew Annihilator (Model- SM-RS-CDA-R)** Configuration .

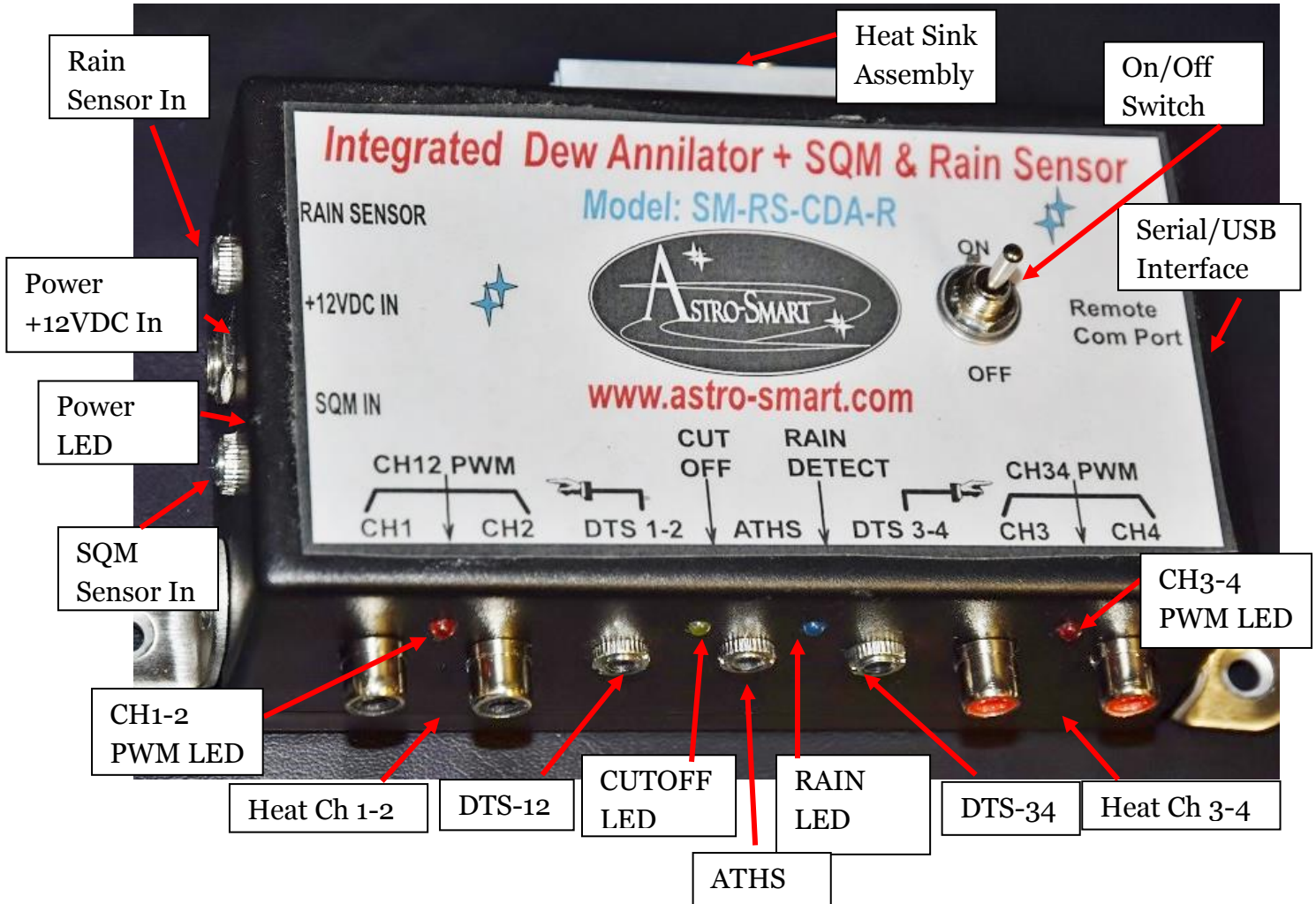



Providing the Astronomical Community with Premier Products and Services

Astro-smart.com

Copyright © 2010-2049, All rights reserved

Jan 2020

➤ Computerized Dew Annihilator (Model-OC-RS-CDA-R) Configuration .

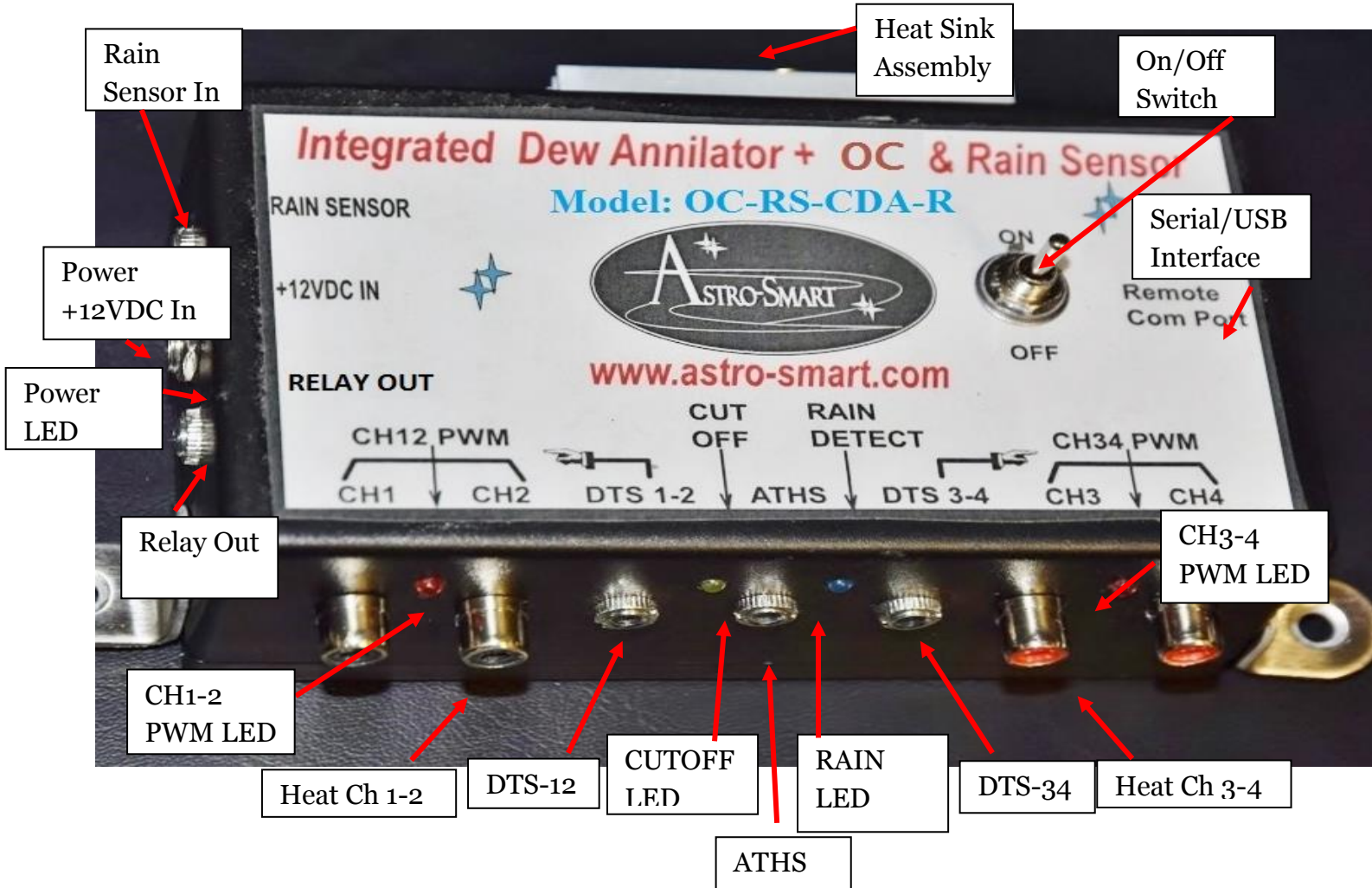



Providing the Astronomical Community with Premier Products and Services

Astro-smart.com

Copyright © 2010-2049, All rights reserved

Jan 2020

➤ Computerized Dew Annihilator (Model- **SM-CDA-R**) Configuration .

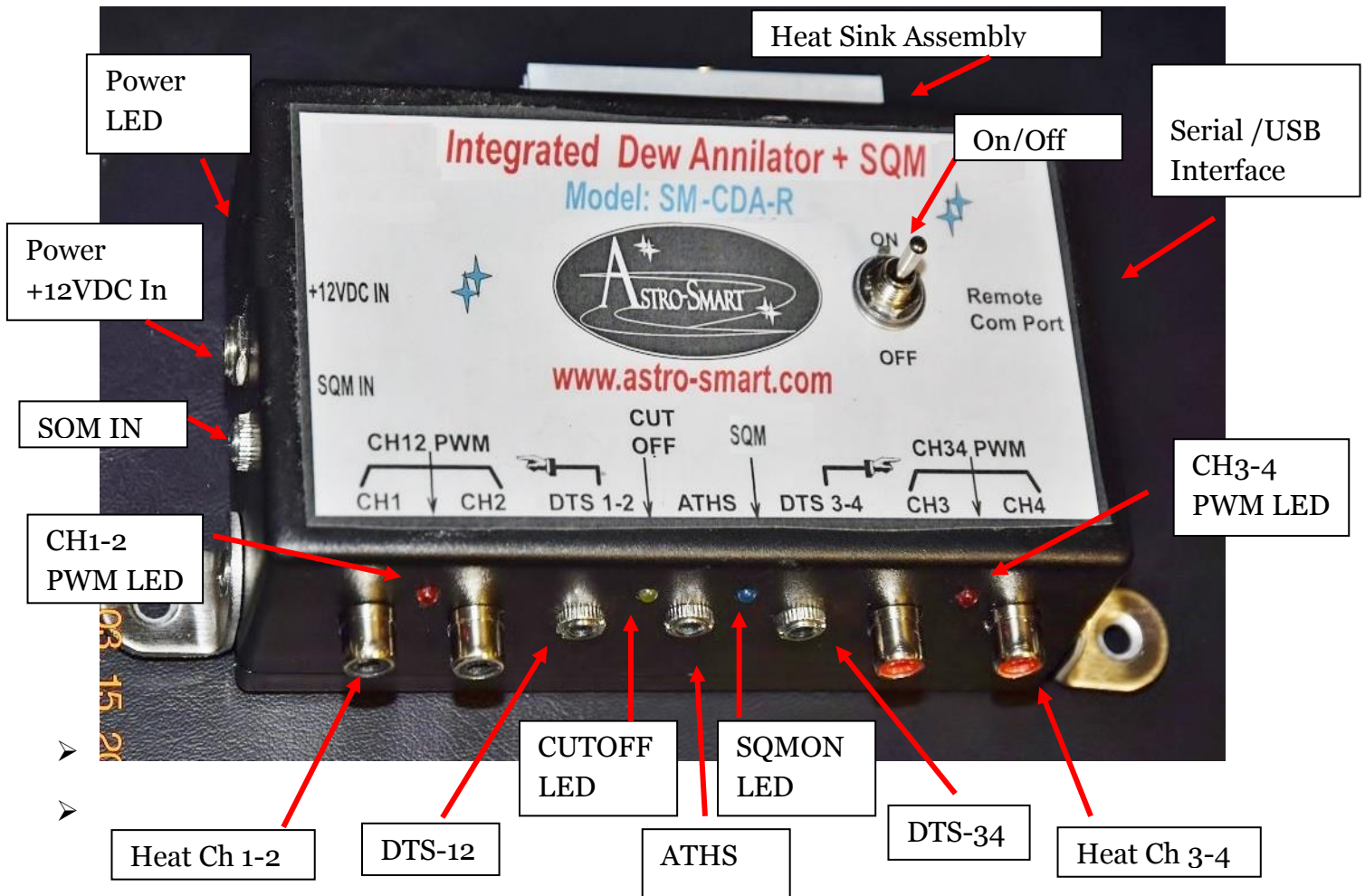



Providing the Astronomical Community with Premier Products and Services

Astro-smart.com

Copyright © 2010-2049, All rights reserved

Jan 2020

➤ Computerized Dew Annihilator (Model- **RS-CDA-R**) Configuration .

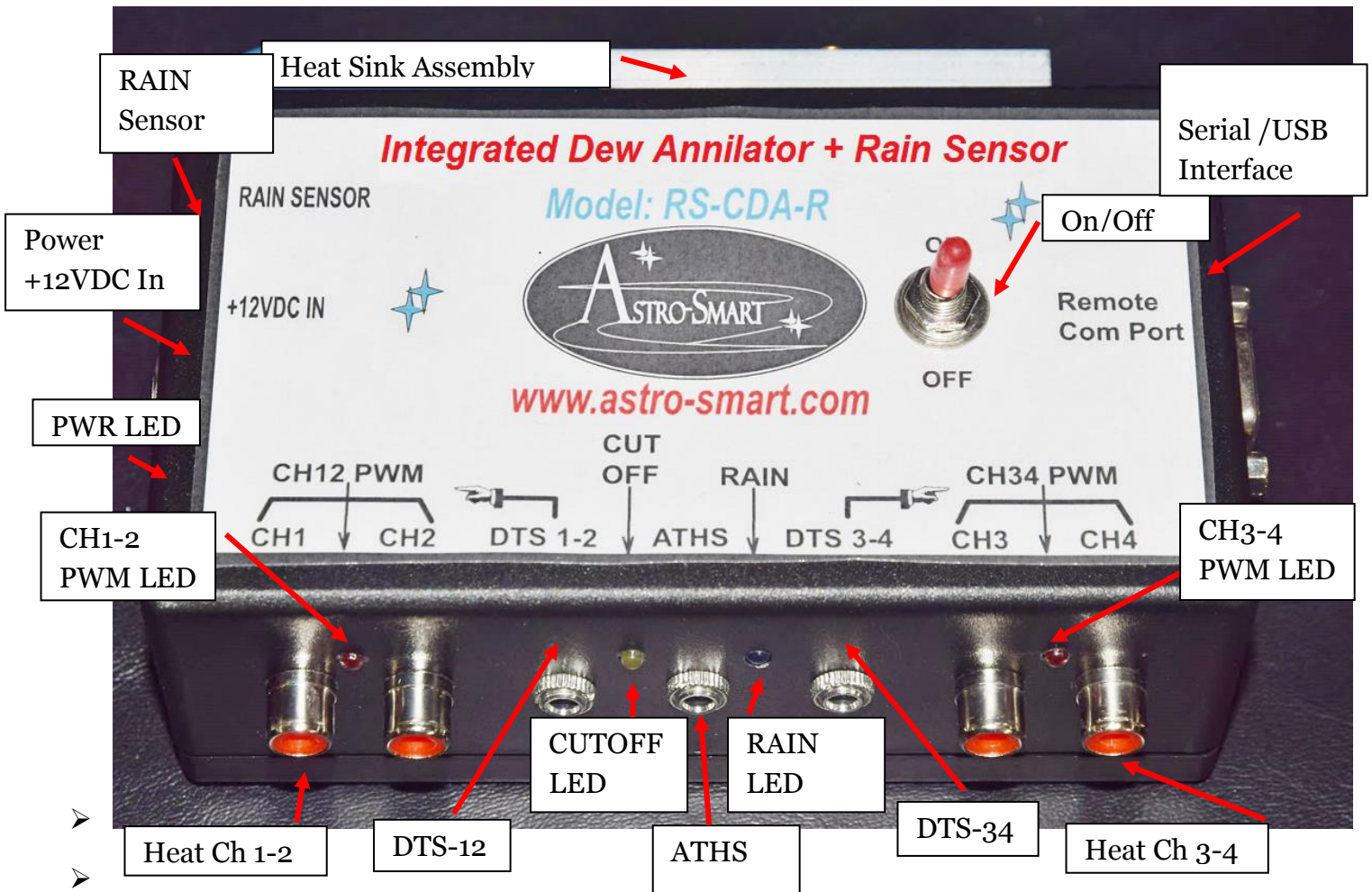



Providing the Astronomical Community with Premier Products and Services

Astro-smart.com

Copyright © 2010-2049, All rights reserved

Jan 2020

➤ Computerized Dew Annihilator (Model- RC-CDA-R) Configuration.

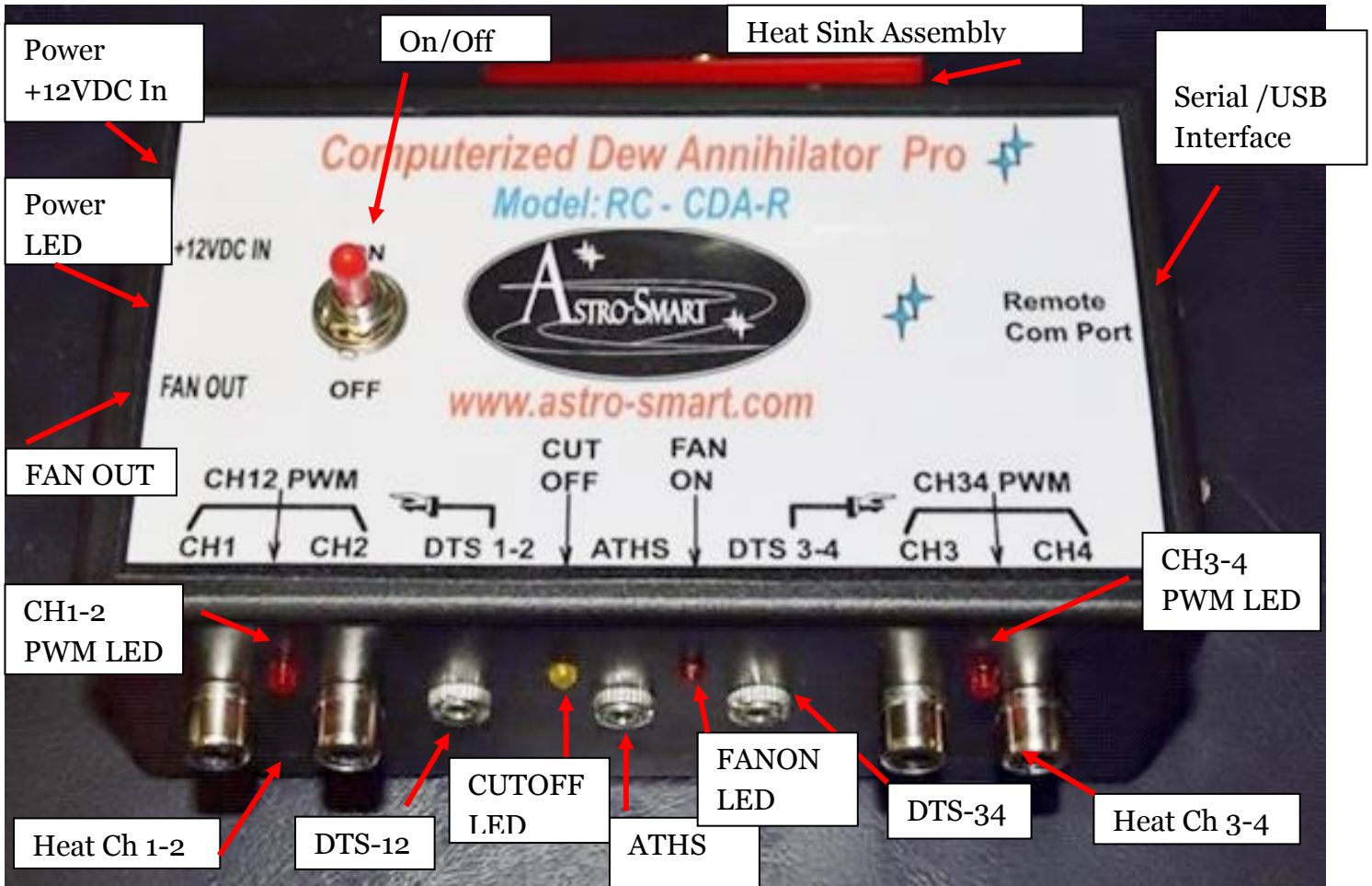



Providing the Astronomical Community with Premier Products and Services

Astro-smart.com

Copyright © 2010-2049, All rights reserved

Jan 2020

➤ Computerized Dew Annihilator (Model- **CDA-R**) Configuration.

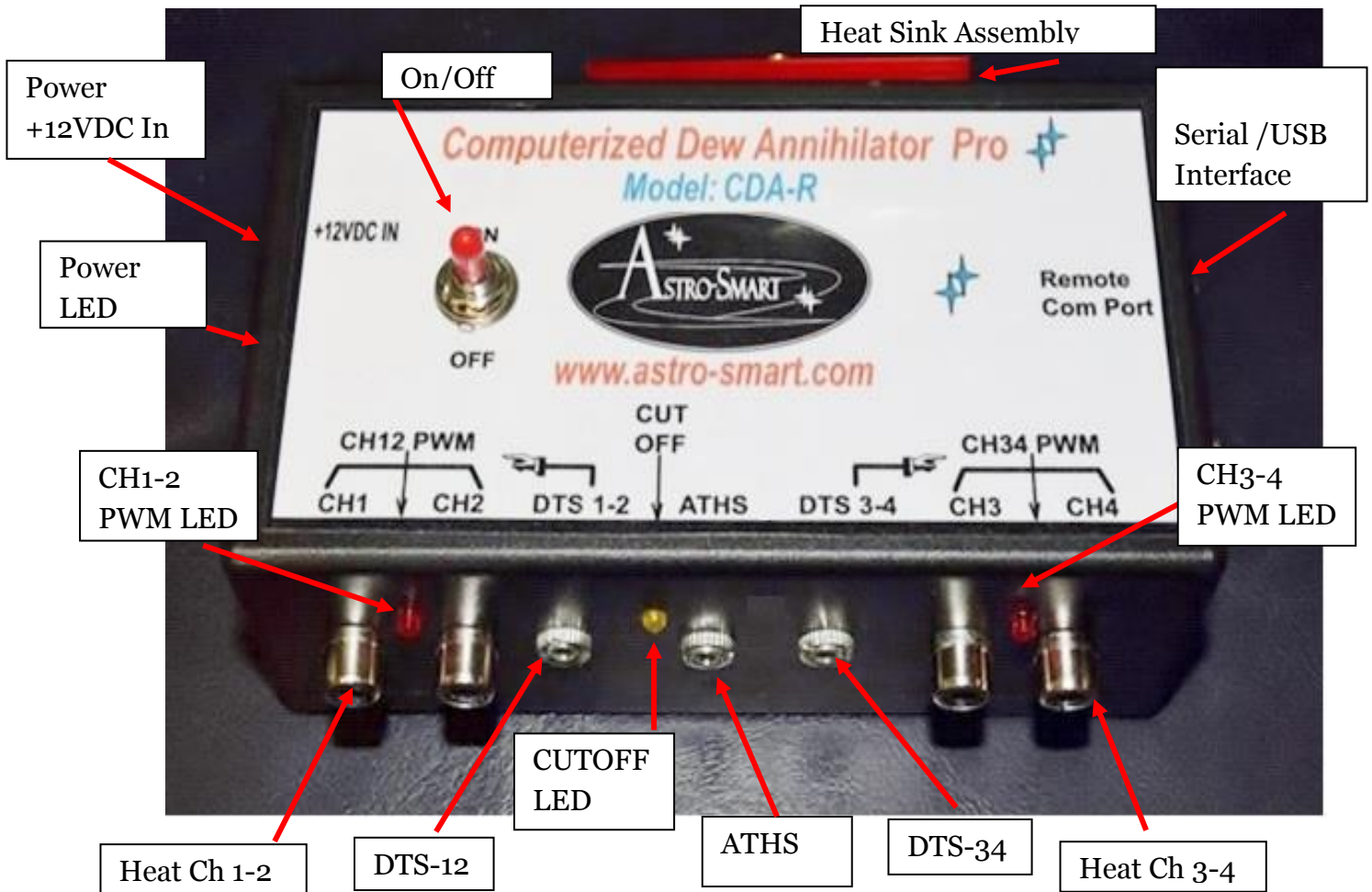



Providing the Astronomical Community with Premier Products and Services

Astro-smart.com

Copyright © 2010-2049, All rights reserved

Jan 2020

G. Basic Functionality Auto Mode Vs. Manual Mode

The user can watch as the **CDA-R FAMILY controller** adjusts heat and controls dew on your telescope based on humidity, dew point, local ambient and temperature differential from optical interfaces with the surrounding environmental conditions. The automatic bootup default control summary features are explained below with user override options for manual control during standard operation described below in next section.

CDA-R, RS-CDA-R, SM-CDA-R, SM-RS-CDA-R, OC-RS-CDA-R Functionality:

The CDA-R variants above are designed for any telescope that requires optic heating for removal of dew. These variants have 2 modes of operation auto mode and manual mode. In general, Auto mode means the system takes ownership of all decisions based on environmental dew and temperature conditions to your scope setup for when and how much heat to apply to the optics for dew removal. Manual mode gives control to the user to specify how much heat to apply to all available channels bypassing auto mode and the need for temperature monitoring. The specifics of these modes are described below.

1. Auto mode:

- a. Differential temperature of optics (DTS sensors) and ambient(AHTS) monitored.
- b. Heat applied to optics when temperature of optics below ambient.
- c. Heat profile regarding aggressiveness can be adjusted by user. This means the differential delta of temperature between optics and ambient can be programmed for how much heat to apply and when. The profile is shown in the GUI.
- d. All 4 channels can be in auto mode split between 2 DTS temp sensors. That is CH1/2 control based on DTS12 and CH3/4 control based on DTS34 readings.
- e. Humidity and dewpoint monitoring profile part of temperature profile programmable by user. The profile is shown in the GUI.

2. Manual mode:

- a. All 4 channels can be placed in manual mode to control heat on optics regardless of auto programmed temperature profile specified. In manual mode all channels can be programmed a % of power to the optics where temperature/humidity monitoring is still visible. Manual mode message will be displayed along channels selected for this mode.



Providing the Astronomical Community with Premier Products and Services

Astro-smart.com

Copyright © 2010-2049, All rights reserved

Jan 2020

RC-CDA-R Functionality:

The RC-CDA-R is designed for RC telescopes that requires optic heating of primary/secondary mirror and cooling of primary mirror for removal of dew. With the RC-CDA-R system, CH1/2 are dedicated to the secondary mirror of your RC while CH3/4 are dedicated for your primary mirror. The secondary mirror will always require heating or not heating while the primary will require heating and cooling in order to maintain dew removal optimization. The RC-CDAR has 2 modes of operation auto mode and manual mode. In general, Auto mode means the system takes ownership of all decisions based on environmental dew and temperature conditions to your scope setup for when and how much heat and cooling to apply to the optics for dew removal. Manual mode gives control to the user to specify how much heat to apply to all available channels bypassing auto mode and the need for temperature monitoring. The specifics of these modes are described below.

1. Auto mode:

- a. Differential temperature of optics (DTS sensors) and ambient(AHTS) monitored.
- b. Primary and Secondary Mirror: Heat applied to optics when temperature of optics below ambient.
- c. Primary and Secondary Mirror: Heat profile regarding aggressiveness can be adjusted by user. This means the differential delta of temperature between optics and ambient can be programmed for how much heat to apply and when. The profile is shown in the GUI.
- d. Secondary Mirror: CH1/2 channels can be in auto mode with DTS12 temp sensor. That is CH1/2 heat control based on DTS12 readings.
- e. Primary Mirror: CH3/4 channels can be in auto mode with DTS34 temp sensor. That is CH3/4 heat and cooling control based on DTS34 readings. If the delta temp positive meaning optic temp > ambient, cooling is applied and If negative heating is applied.
- f. Humidity and dewpoint monitoring profile part of temperature profile programmable by user for all channels. The profile is shown in the GUI.

2. Manual mode:

- a. All 4 channels can be placed in manual mode to control heat on optics regardless of auto programmed temperature profile specified. In manual mode all channels can be programmed a % of power to the optics where temperature/humidity monitoring is still active and visible.
- b. Secondary Mirror: CH1/2 channels can be in manual mode where a % power is applied to optics and temperature/humidity monitoring is still active and visible.
- c. Primary Mirror: CH3/4 channels can be in manual mode where a % power is applied to optics and temperature/humidity monitoring is active and visible. When in this mode also allows manual fan mode operation in the GUI. When used with a timer if desired, the manual heat operation is disabled. Generally, this option is used when you start a telescoping session and



Providing the Astronomical Community with Premier Products and Services

Astro-smart.com

Copyright © 2010-2049, All rights reserved

Jan 2020

you just want to cool down your telescope optics for a set time say 30 minutes before you start an telescoping session.

H. CDAR Setup and BootUp: Default

1. Fix all connections to your **CDA-R FAMILY controller** This includes heater straps CH1/CH2 and both temperature sensor plugged in DTS12 and DTS34 with power supply interface and USB cable connected to computer.
2. Turn On power switch from center(OFF) to Up position(ON).. Boot up sequence. All functions are a go when the “Beep” is heard.

*Note:” **CDA-R FAMILY controller** Requires all DTS’s sensors Plugged IN.”*

*Note:” The **CDA-R FAMILY controller** requires a complete circuit meaning the heat straps being plugged in to provide current drawl and heat applied to the optics.”*

Online video demo’s of operation can be found on our website at :

http://www.astro-smart.com/index.php?p=1_24



Providing the Astronomical Community with Premier Products and Services

Astro-smart.com

Copyright © 2010-2049, All rights reserved

Jan 2020

I. Standard WebGUI PC Dew Control Remote User Interface Summary

Your **CDA-R FAMILY controller** can be monitored or controlled from your computer. Just connect the serial to usb cable and in the device manager of your operating system, you must know what port is used when connected. The settings will be automatic and the host PC install program provided will list all available serial ports to connect. You just pick the correct one. A video tutorial is listed in the support page of our website for basic operations of this feature. Some basic features are listed below.

❖ GUI SETUP:

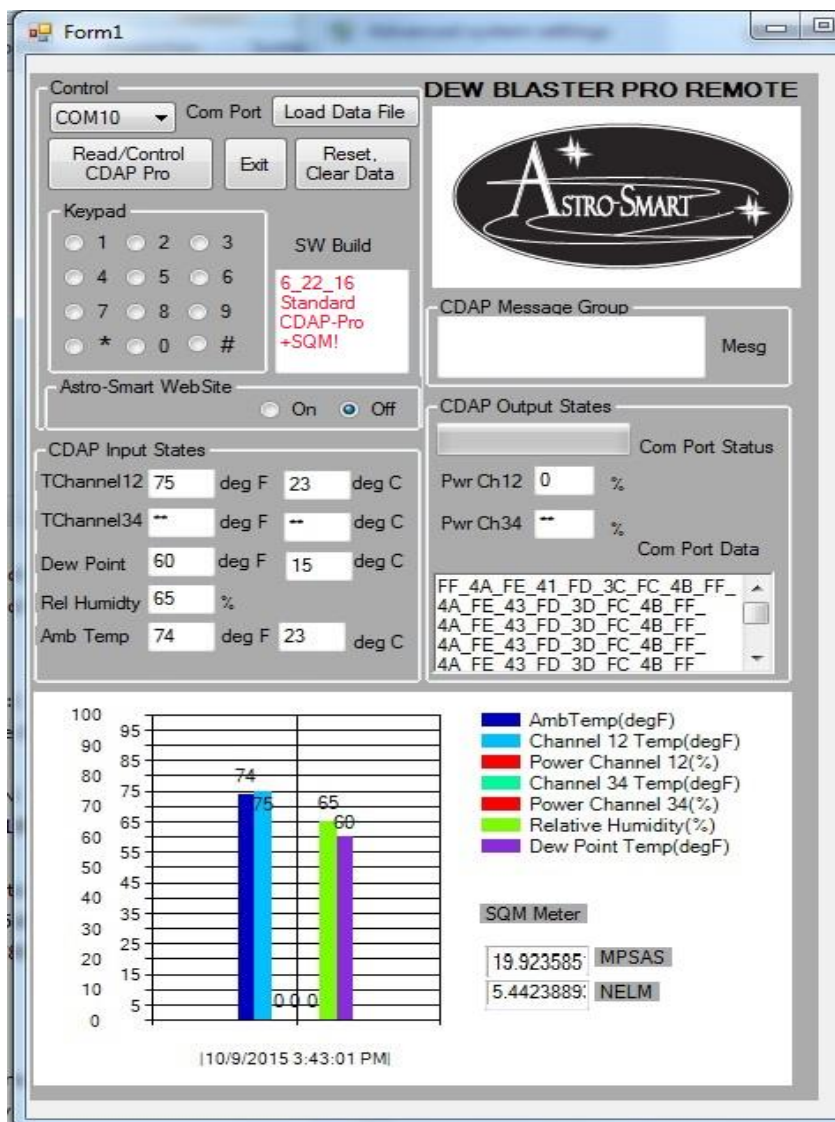

BASIC CDA-R Standard Interface.

The simplicity of operation can be seen in the following figure.

❖ The HW/SW requirements for the CDA-R FAMILY controller to work with PC communication are the following:

1. Connect serial to USB cable provided by Astro-Smart.
2. Install the **CDA-R** SW on computer (Win XP-Win 10).
3. Wait for USB drivers to install automatic.
4. Turn on the **CDA-R FAMILY controller**, then run the device manager on your PC OS to determine which port the **CDA-R FAMILY controller** is attached to. Then run the **CDA-R** SW..
5. While in **CDA-R** PC interface, select the serial port **CDA-R FAMILY controller** is attached to.



Providing the Astronomical Community with Premier Products and Services

Astro-smart.com

Copyright © 2010-2049, All rights reserved

Jan 2020

*Note: When using your **CDA-R FAMILY controller**, operation on the computer keypad software interface should perform as if you had a standalone **CDA-R FAMILY controller** with display and keypad. Instructions shown below are the same regardless if you enter keystrokes on the physical keypad on a **CDA-R FAMILY controller** or using the simulated keypad SW interface..*

❖ **GUI OPERATION:**

- 1.. Select **Read/Control button** and watch the data arrive in the Output status window.
2. In about 5-8 secs, the data will be parsed and reported in I/O status window and also on the graphic output. Anytime, you wish to update from the device, simply press this button again using the standard CDAP-Pro SW interface. Using the super CDAP-Pro SW enables real time monitor and or control as explained later.
3. In this mode you query the **CDA-R FAMILY controller** without the use of the SW keypad in the WebGUI.

❖ **Examples: Basic DEW Control Operation**

The method for controlling unit is by select key strokes on the SW keypad while the SW is collecting data in the Output status window.

- A. If it is desired to manually set the power on the **CDA-R-PRO FAMILY controller** 40% on CH12 the sequence would be:
 1. Hit Read/Control button.
 2. Then Press the “7” on keypad, wait 2 secs then press “2” on the keypad interface.
- B. To Reset the unit and return to Auto Mode as default.
 1. Hit Read/Control button.
 2. Then Press the “*” on keypad.



Providing the Astronomical Community with Premier Products and Services

Astro-smart.com

Copyright © 2010-2049, All rights reserved

Jan 2020

❖ **Examples: Data Logging and File Retrieval**

❖ **Automatic Data File Logging Feature->Saving, Retrieval and Plotting.**

This feature is very powerful when wanting to collect and compare prior data results from your **CDA-R FAMILY controller** as a data logger. To perform this operation, do the following below.

1. After performing and collecting multiple samples from your **CDA-R FAMILY controller** using the Read/Control **CDA-R FAMILY controller** button, the system automatically stores the files on your hard drive in C:\CDA-Pro_Data directory.
2. Hit the Load Data File button and the software takes you to the directory to select a file of interest. The files are time stamped and will be recognized by the program when loaded. These files are plotted and data is shown with the prior history time stamp to compare and or retrieve data taken from prior night sessions.
3. The figures below show this behavior.

http://www.astro-smart.com/index.php?p=1_49_Video-Overviews

This link above is for the video tutorials.



Providing the Astronomical Community with Premier Products and Services

Astro-smart.com

Copyright © 2010-2049, All rights reserved

Jan 2020

❖ Automatic Data Logger and File Retrieval Plotting Capability:

The screenshot displays three overlapping windows from the DEW BLASTER PRO REMOTE software. The leftmost window is the main control panel, featuring a keypad, 'Read/Control CDAP Pro' and 'Reset, Clear Data' buttons, and various input state fields for temperature and humidity. The middle window is a file explorer showing a directory of CDAP data files. The rightmost window, titled 'Form1', shows a detailed control panel with a keypad, a status display showing '6_22_16 Standard CDAP-Pro +SQM!', and a bar chart plotting temperature and humidity data over time. The chart shows values for Ambient Temp (74), Channel 12 Temp (75), Channel 34 Temp (65), Power Channel 12 (0.0), Power Channel 34 (0.0), Relative Humidity (65), and Dew Point Temp (60).

Enhancements to the software will be made based on user input on a continual basis and can be uploaded from our site for your convenience.



Providing the Astronomical Community with Premier Products and Services

Astro-smart.com

Copyright © 2010-2049, All rights reserved

Jan 2020

❖ Super **CDA-R-PRO FAMILY controller** Software Suite Capability:

The super professional version upgrade of the software increases the capability of your CDAP pro to even a higher level. This includes a data acquisition and processing suite for Multi-Channel Real Time Data Acquisition, User Selectable Dew Channel Power Aggressiveness Curves, Variable Acquisition Rate, Bias Offset Selection, File Storage and Plot Retrieval for Extended Regression Data Analysis including .csv, .txt, .png file formats for easy interface to Office Products(Excel, etc), integration with advanced sensors such a rain and SQM, Observatory Relay control and a Simulator Trainer Mode. Snapshot shown below.

Several versions of this software are available depending on product purchase. Various package snapshots are shown below. Each package is made available to evaluate for each customer purchase.

New Power Curve Selection, Bias Offset Interface, Log Save ON/OFF and New Auto/Manual mode indicators with all temperature channels active.....

See video tutorials on website for actual demonstrations.

http://www.astro-smart.com/index.php?p=1_49_Video-Overviews



Providing the Astronomical Community with
Premier Products and Services

Astro-smart.com

Copyright © 2010-2049, All rights reserved

Jan 2020

CDAP-PRO FAMILY controller Super Real Time Data Acquisition and Regression

The screenshot displays the CDAP/CDA-R Super SW interface, which is divided into several functional areas:

- Control Panel:** Includes a COM2 dropdown, Refresh Ports, and Exit buttons. A keypad is visible with a function call for CH1234 or DTS12. The software build date is 06-23-19.
- DataControl Panel:** Features buttons for Static Read Control, Clear Data, Real Time Read Control, and Stop Real Time Mode. A variable sample rate is set to 10 seconds (900 sec = 15 min max).
- CDAP Input States:** A table showing real-time data for various sensors:

TChannel12	79 degF	26 degC	1
TChannel34	78 degF	25 degC	0
Amb Temp	78 degF	25 degC	0
Dew Point	61 degF	16 degC	
Rel Humidity	38 %		
Desired Humidity Offset			
- CDAP Output Power // CDAP PRO Status:** Shows P12 at 20% (Man Mode) and P34 at 0% (Auto Mode!). A message indicates "Port Open! Real Time Mode Active!".
- Real Time Data Plot:** A line graph showing temperature (AmbTemp, DTS12, DTS34) and humidity (Relative Humidity) over time. The Y-axis ranges from 0 to 100. The X-axis shows timestamps from 2:07:25 PM to 2:16:06 PM.
- Historical Plot Data (Chart1.png):** A bar chart showing power channel usage (Power Channel 12 and 34) and other metrics. Values shown are 78, 78, 61, 38, 20, 0.
- System Indicators:** Includes a Voltage Indicator (11<V<12, Good), Rain Sensor (Disabled), and Rain Indicator (No Rain Detected!).



Providing the Astronomical Community with Premier Products and Services

Astro-smart.com

Copyright © 2010-2049, All rights reserved

Jan 2020

Super CDAP PRO SW Suite:

Control

COM7 Com Port Exit

Keypad: 1 2 3, 4 5 6, 7 8 9, * 0 #

KeyPad Help: CH1234 or DTS12 Function Call

SW Build: 2-23-17

DataControl

Static Read Control Clear Data

Real Time Read Control Stop Real Time Mode

Variable Sample Rate(s): 5

Load Data File Load Plot File

SUPER CDAP VERSION

WWW.ASTRO-SMART.COM

Live Data Or Loaded Data File Historical Plot Data(Chart1.png)

13/5/2017 1:22:37 PM

Read/Parse Status

CDAP Input States

TChannel12: 81 deg F, 27 deg C, 0

TChannel34: 81 deg F, 27 deg C, 0

Amb Temp: 81 deg F, 27 deg C, 1

Rel Humidity: 47 %

Dew Point: 67 deg F, 19 deg C

CDAP Output Power // CDAP PRO Status

0 % P12 Percent Power 0 Current Power Bias Point

0 % P34 Percent Power 0 Desired Power Bias Point

Port Open! Real Time Mode Active!

0 (AHTS - DTS12) degs

0 (AHTS - DTS34) degs

Help Selecting Power Curve (Hoover Mouse Over Button!)

Power Curve Agressiveness

0 Current Power Bias Point

0 Desired Power Bias Point

RealTime Data Historical Plot Data(Chart2.png)

Y Scale Adjust Max

13/5/2017 1:22:07 PM

↔ Tdelta(degs) ↔

	-3	-2	-1	0	1	2	3	4	5
0	0%	0%	0%	0%	20%	40%	60%	80%	100%
1	0%	0%	0%	20%	40%	60%	80%	100%	100%
2	0%	0%	20%	40%	60%	80%	100%	100%	100%
3	0%	20%	40%	60%	80%	100%	100%	100%	100%

↔ Tdelta(degs) ↔

Dew Point Automatic

	-2	-1	0	1	2
80%	80%	100%	100%	100%	80%

↔ Power % ↔



Providing the Astronomical Community with Premier Products and Services

Astro-smart.com

Copyright © 2010-2049, All rights reserved

Jan 2020

Hitting the help button in blue brings up the power distribution curve for user selective aggressiveness for heat on optical channels. Remove mouse from button and the acquisition charting appears. For use of this new interface see the video tutorials on the support page on the website. The power curve aggressiveness selection is shown below. The user can select which power index he wants for heat aggressiveness. This is needed when large optics are used with smaller surface area of heat straps. Sometimes its needed to get a head start on heating the optics on these configurations. An index of 3 is the most aggressive where 60% power is applied to optics when the sensors are at equilibrium.

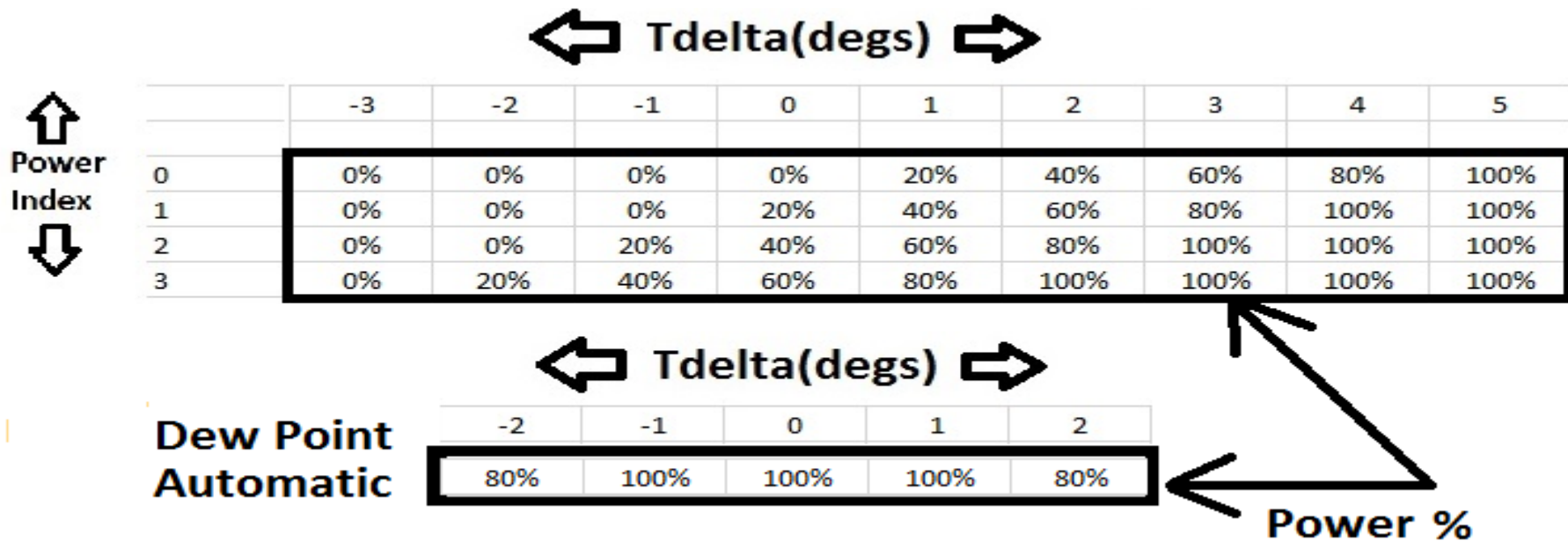



Providing the Astronomical Community with Premier Products and Services

Astro-smart.com

Copyright © 2010-2049, All rights reserved

Jan 2020

Below shows the legacy super pro interface.

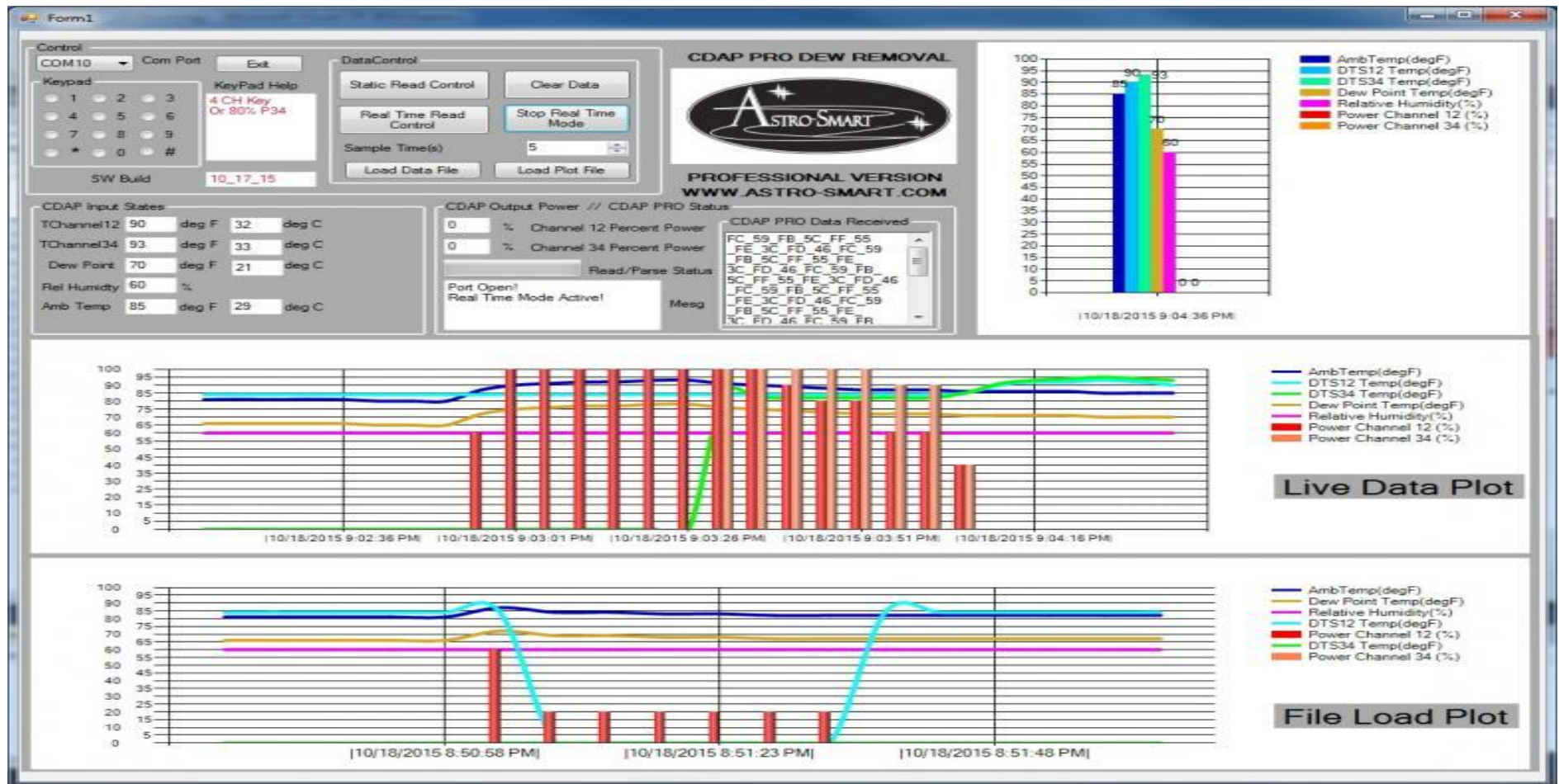



Providing the Astronomical Community with Premier Products and Services

Astro-smart.com

Copyright © 2010-2049, All rights reserved

Jan 2020

CDA-R + SQM + Rain Sensor PRO Super Real Time Data Acquisition and Regression Analysis Suite

Control

COM10 Com Port Exit

KeyPad

1 2 3
4 5 6
7 8 9
* 0 #

KeyPad Help
CH1234 or DTS12
Function Call

SW Build
3-13-17

DataControl

Static Read Control Clear Data

Real Time Read Control Stop Real Time Mode

Variable Sample Rate(s) 5

Load Data File Load Plot File

SUPER CDAP VERSION

WWW.ASTRO-SMART.COM

CDAP Input States

TChannel12 71 deg F 21 deg C 1 1

TChannel34 -- deg F -- deg C

Amb Temp 71 deg F 21 deg C 0

Rel Humidity 42 %

Dew Point 55 deg F 12 deg C

CDAP Output Power // CDAP PRO Status

0 % P12 Percent Power Current Power Bias Point

0 % P34 Percent Power Desired Power Bias Point

0 (AHTS - DTS12) degs Port Open!

0 (AHTS - DTS34) degs Real Time Mode Active!

Help Selecting Power Curve (Hoover Mouse Over Button!)

Live Data Or Loaded Data File Historical Plot Data(Chart1.png)

13/15/2017 9:41:14 AM

Read/Parse Status

SQM	19.93	MPSAS
	5.45	NELM

RealTime Data Historical Plot Data(Chart2.png) Real Time SQM Data Historical SQM Plot Data(Chart3.png)

Y Scale Adjust Max

13/15/2017 9:40:39 AM 13/15/2017 9:40:49 AM 13/15/2017 9:41:01 AM 13/15/2017 9:41:09 AM

Indicators:

Voltage Indicator: 11<V<12, Good

SQM Indicator: SQM Sensor Activated! plugged in!

Rain Indicator: Rain Sensor Activated! No Rain Detected!

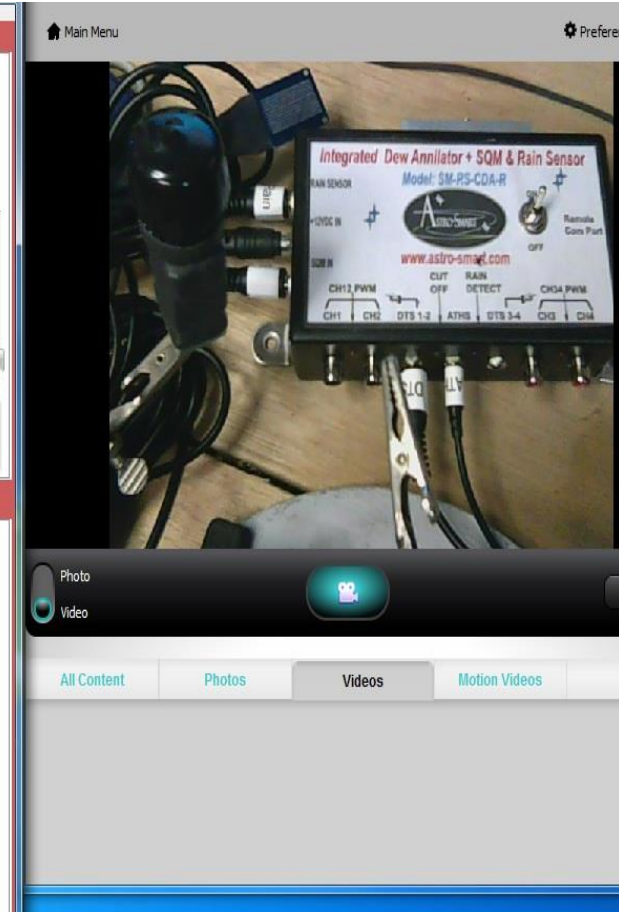



Providing the Astronomical Community with Premier Products and Services

Astro-smart.com

Copyright © 2010-2049, All rights reserved

Jan 2020

CDA-R + Rain Sensor PRO Super Real Time Data Acquisition and Regression Analysis Suite

The screenshot displays the 'SUPER CDAP VERSION' software interface. The top section includes control buttons like 'Refresh Ports', 'Exit', and 'DataControl'. A keypad is visible on the left. The main area features a 'Live Data Or Loaded Data File' plot showing various parameters: AmbTemp (87.87), DTS12 Temp (87), DTS34 Temp (87), Dew Point Temp (41), Relative Humidity (19), Power Channel 12 (00), and Power Channel 34 (00). Below the plot are 'CDAP Input States' and 'CDAP Output Power' settings. A 'Rain Sensor Enable' button is highlighted. The bottom section shows a 'Real Time Data' plot with a Y-axis from 0 to 100 and X-axis from 9/7/2018 1:11:29 PM to 1:15:29 PM. A legend on the right lists the data series. A hex dump is visible at the bottom right of the plot area.

On the right, a camera view shows the physical hardware unit, a 'Computerized Dew Annihilator Pro Model RS-CDAP-R'. The unit has a screen displaying the Astro-Smart logo and website, and several ports labeled 'DTS12 POWER', 'DTS34 POWER', 'RAIN', 'DTS12', and 'DTS34'. A 'Rain Sensor Enable' button is visible on the front panel.



Providing the Astronomical Community with Premier Products and Services

Astro-smart.com

Copyright © 2010-2049, All rights reserved

Jan 2020

CDA-R + SQM PRO Super Real Time Data Acquisition and Regression Analysis Suite

The screenshot displays the 'Form1' software window for 'SUPER CDAP + SQM'. The interface includes a control panel with a keypad, data control buttons (Static Read Control, Real Time Read, Stop RT Read, Load Data File, Load Plot File), and a status section showing 'CDAP Input States' (TChannel12, TChannel34, Dew Point, Rel Humidity, Amb Temp) and 'CDAP Output Power // CDAP PRO Status' (P12, P34 Percent Power, SQM, MPSAS, NELM). A 'Live Data Or Loaded Data File' section shows a bar chart with values: 86, 76, 54, 20, 20. The bottom section features a 'Real Time CDAP Data' plot showing 'MPSAS(Mag/sqr arcsec)' (blue line) and 'NELM(Theoretical)' (orange area) over time from 8:40:54 PM to 8:42:19 PM on 8/8/2016.

To the right, the 'Logitech Webcam Software' window shows a live video feed of the 'Integrated Dew Annihilator + SQM' hardware device (Model: SM-CDA-R) with various sensors and cables connected. The device has a keypad and a status indicator.



Providing the Astronomical Community with Premier Products and Services

Astro-smart.com

Copyright © 2010-2049, All rights reserved

Jan 2020

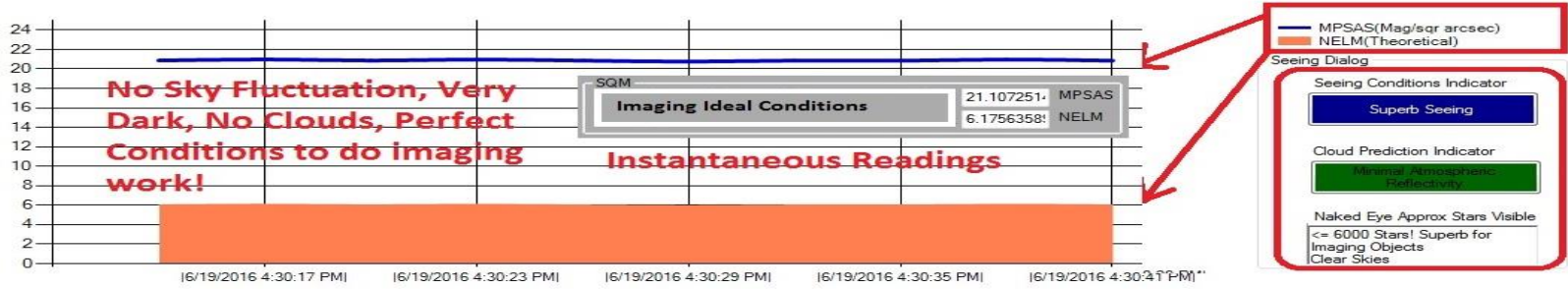
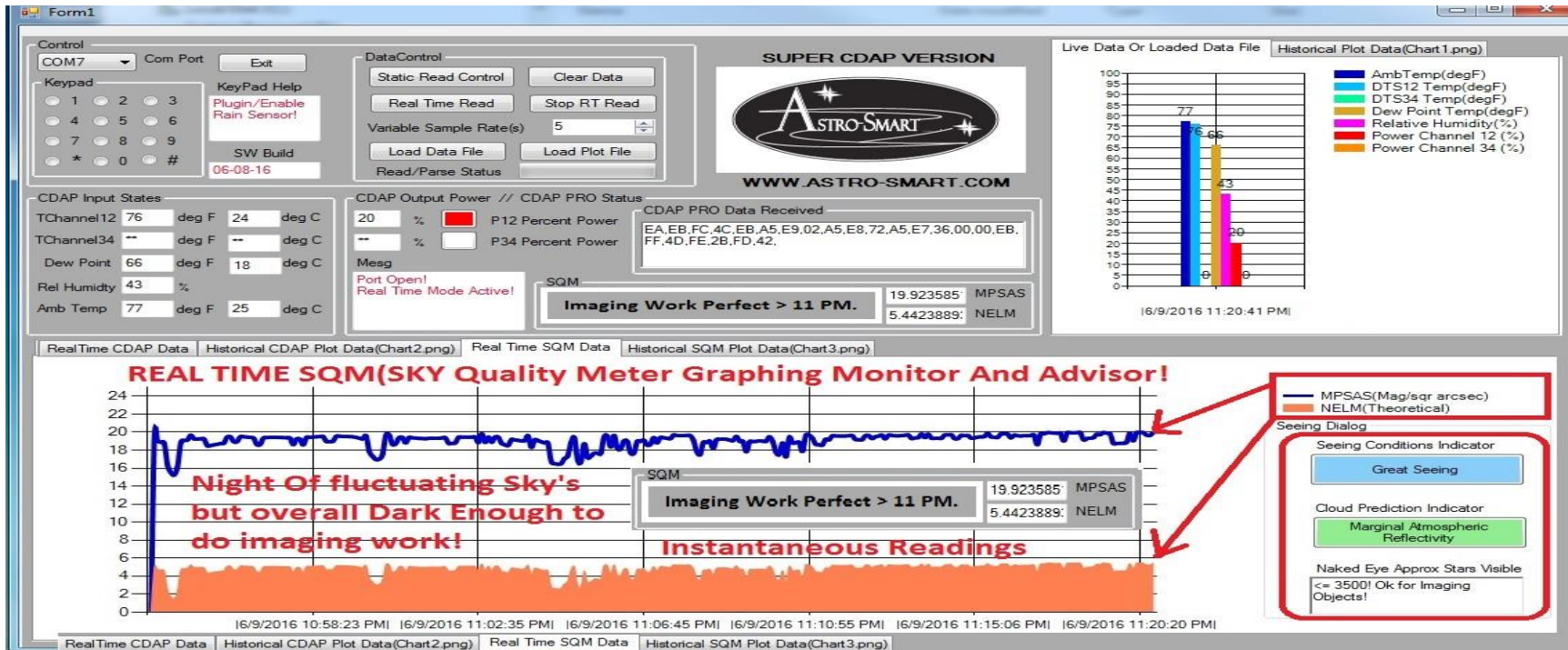



Providing the Astronomical Community with Premier Products and Services

Astro-smart.com

Copyright © 2010-2049, All rights reserved

Jan 2020

Software Algorithm: SQM and NELM Calculations

Pulse Width(uc) (Hex)	Pulse Width(uc) (Dec)	Period (Seconds)	Frequency (Hz)	SQM (Magnitude/arcsec 2)	NELM (Naked Eye SQM)
1	1.00	2.00	250,000.00	6.458337024	-7.193715161
2	2.00	4.00	125,000.00	7.210912014	-6.441989646
3	3.00	6.00	83,333.33	7.651140161	-6.002413099
4	4.00	8.00	62,500.00	7.963487003	-5.690615429
5	5.00	10.00	50,000.00	8.205762035	-5.448824112
6	6.00	12.00	41,666.67	8.40371515	-5.251308217
8	8.00	16.00	31,250.00	8.716061992	-4.939737456
A	10.00	20.00	25,000.00	8.958337024	-4.698145934
D	13.00	26.00	19,230.77	9.243195405	-4.41419476
10	16.00	32.00	15,625.00	9.468636981	-4.189560147
14	20.00	40.00	12,500.00	9.710912014	-3.948250616
19	25.00	50.00	10,000.00	9.953187046	-3.707054539
1F	31.00	62.00	8,064.52	10.18674126	-3.474660239
27	39.00	78.00	6,410.26	10.43599854	-3.2267857
31	49.00	98.00	5,102.04	10.68382722	-2.980497507
3D	61.00	122.00	4,098.36	10.92166161	-2.744315121
4C	76.00	152.00	3,289.47	11.16037101	-2.507454619
5F	95.00	190.00	2,631.58	11.40264604	-2.267273993
77	119.00	238.00	2,100.84	11.64720443	-2.02507813
95	149.00	298.00	1,677.85	11.8913027	-1.783615732
BA	186.00	372.00	1,344.09	12.13211938	-1.545702913
E9	233.00	466.00	1,072.96	12.37672683	-1.304389216
123	291.00	582.00	859.11	12.6180695	-1.066675247
16C	364.00	728.00	686.81	12.86109048	-0.827732094
1C7	455.00	910.00	549.45	13.10336552	-0.589993983
239	569.00	1,138.00	439.37	13.34611769	-0.352313565
2C7	711.00	1,422.00	351.62	13.58801103	-0.116056752
379	889.00	1,778.00	281.21	13.83059143	0.120221367
457	1,111.00	2,222.00	225.02	14.07262217	0.355243345
56D	1,389.00	2,778.00	179.99	14.31509264	0.589890375
6C8	1,736.00	3,472.00	144.01	14.55721133	0.82330799
87A	2,170.00	4,340.00	115.21	14.79948636	1.055890131



Providing the Astronomical Community with Premier Products and Services

Astro-smart.com

Copyright © 2010-2049, All rights reserved

Jan 2020

A99	2,713.00	5,426.00	92.15	15.04196151	1.287569889
D3F	3,391.00	6,782.00	73.72	15.2841565	1.517771989
108F	4,239.00	8,478.00	58.98	15.52649557	1.746772691
14B3	5,299.00	10,598.00	47.18	15.76882182	1.974282964
19E0	6,624.00	13,248.00	37.74	16.01113783	2.200153363
2058	8,280.00	16,560.00	30.19	16.25341287	2.424190823
286E	10,350.00	20,700.00	24.15	16.4956879	2.646255361
328A	12,938.00	25,876.00	19.32	16.73800489	2.866192766
3F2D	16,173.00	32,346.00	15.46	16.98031349	3.083750743
4EF8	20,216.00	40,432.00	12.37	17.2225751	3.298675431
62B6	25,270.00	50,540.00	9.8932	17.46485013	3.510787314
7B64	31,588.00	63,176.00	7.9144	17.70714235	3.719842406
9A3D	39,485.00	78,970.00	6.3315	17.94941738	3.925552216
CoCC	49,356.00	98,712.00	5.0652	18.19168691	4.127657577
FoFF	61,695.00	123,390.00	4.0522	18.43396195	4.32588918
12D3F	77,119.00	154,238.00	3.2417	18.6762405	4.519960054
1788F	96,399.00	192,798.00	2.5934	18.91851835	4.709577753
1D6B3	120,499.00	240,998.00	2.0747	19.16079563	4.894452862
24C60	150,624.00	301,248.00	1.6598	19.40307247	5.074299117
2DF78	188,280.00	376,560.00	1.3278	19.6453475	5.248836542
39756	235,350.00	470,700.00	1.0622	19.88762253	5.417799273
47D2C	294,188.00	588,376.00	0.8498	20.12989941	5.580937821
59C77	367,735.00	735,470.00	0.6798	20.37217444	5.738020258
70395	459,669.00	919,338.00	0.5439	20.61445006	5.888844692
8C47A	574,586.00	1,149,172.00	0.4351	20.85672462	6.03323689
AF599	718,233.00	1,436,466.00	0.3481	21.09900041	6.17105918
DB2FF	897,791.00	1,795,582.00	0.2785	21.34127514	6.302208661
111FBF	1,122,239.00	2,244,478.00	0.2228	21.58355042	6.426624505
1567AF	1,402,799.00	2,805,598.00	0.1782	21.82582564	6.544286055
1AC19B	1,753,499.00	3,506,998.00	0.1426	22.06810083	6.655214876
217202	2,191,874.00	4,383,748.00	0.1141	22.31037599	6.759473886
29CE83	2,739,843.00	5,479,686.00	0.0912	22.55265122	6.857165859
344224	3,424,804.00	6,849,608.00	0.0730	22.79492633	6.948430802
4152AD	4,281,005.00	8,562,010.00	0.0584	23.03720136	7.033442906
51A758	5,351,256.00	10,702,512.00	0.0467	23.27947634	7.112406525
66112E	6,689,070.00	13,378,140.00	0.0374	23.52175138	7.185551826
7F957A	8,361,338.00	16,722,676.00	0.0299	23.76402647	7.253130068



Providing the Astronomical Community with Premier Products and Services

Astro-smart.com

Copyright © 2010-2049, All rights reserved

Jan 2020

		20,903,346.0			
9F7AD9	10,451,673.00	0	0.0239	24.00630156	7.315408862
C7598F	13,064,591.00	26,129,182.00	0.0191	24.24857657	7.372667511
F92FF3	16,330,739.00	32,661,478.00	0.0153	24.49085162	7.425192568
		33,554,430.0			
FFFFFF	16,777,215.00	0	0.0149	24.5201367	7.431234745



Providing the Astronomical Community with Premier Products and Services

Astro-smart.com

Copyright © 2010-2049, All rights reserved

Jan 2020

J. Summary WebGUI Entry Commands (System Control)

Note: Use WebGUI entry instructions below when using buttons on simulated keypad on the PC software interface.

Note: Picture examples of modes are shown below of what to expect in MSG window on the CDAP-Pro Display CDU before the system responds to the user action invoked. Otherwise, if using the remote PC SW interface, the message box will display the meaning of the following used keys below.

- **‘ 1’ Enter:** *on WEBGUI is used if user wishes to set a **variance setpoint between ambient and optic temperature DTS CH1-2** or re-calibrate DTS CH1-2 channel. This has been done at factory. Default activation on power up and reset user modification from sensor value. For example pressing 1 followed by another 1 in subtraction mode will cause DTS CH1-2 to be lowered by 1 deg F. If it is desired to add value to DTS CH1-2, mode 5 must be pressed to go into add mode before performing operation. See below in option 5.*
- **‘ 2’ Enter:** *on WEBGUI is used if user wishes to set a **variance setpoint between ambient and optic temperature DTS CH3-4** or re-calibrate DTS CH3-4 channel. This has been done at factory. Default activation on power up and reset user modification from sensor value. For example pressing 2 followed by another 1 in subtraction mode will cause DTS CH3-4 to be lowered by 1 deg F. If it is desired to add value to DTS CH3-4, mode 5 must be pressed to go into add mode before performing operation. See below in option 5.*
- **‘ 3’ Enter:** *on WEBGUI is used if user wishes to set a **variance setpoint between optics and ambient temperature T ambient(ATHS)** or re-calibrate ATHS channel. This has been done at factory. Default activation on power up and reset user modification from sensor value. For example pressing 3 followed by another 1 in subtraction mode will cause ATHS to be lowered by 1 deg F. If it is desired to add value to ATHS, mode 5 must be pressed to go into add mode before performing operation. See below in option 5.*
- **‘ 4’ Enter:** *on WEBGUI for all models are used if user wishes to change the power distribution algorithm for aggressiveness of heat applied to optics. The higher the index, the more heat is applied. A “4” then “0” applies index 0, 4” then “1” applies index 1. See video tutorials for this feature.*
- **‘ 5’ Enter:** *on WEBGUI is used if user wishes to set a **variance add mode setpoint** between sensors by using a value offset in add mode. This has been done at factory. Default activation on power up and reset subtracts from sensor value. For example pressing 5 followed by a 1 and then another 1 will cause DTS CH1-2 to be increased by 1 deg F. If it is desired to return to subtract mode, either reset the system or use the mode 6 button to return to subtract value mode.*



Providing the Astronomical Community with Premier Products and Services

Astro-smart.com

Copyright © 2010-2049, All rights reserved

Jan 2020

- **'6' Enter:** on WEBGUI is used if user wishes to set a **variance subtract setpoint** between sensors by using a value offset in subtract mode. This has been done at factory. Default activation on power up and reset subtracts from sensor value. For example pressing 6 followed by a 1 and then another 1 will cause DTS CH1-2 to be decreased by 1 deg F.

- **'7' Enter :** on WEBGUI to enter **CDA-R FAMILY controller full manual operation mode for all 4 channels**. The user will have the ability to manually operate dew power to straps. In this mode all sensor monitoring is ignored from automatic mode and will not be displayed. Only the output power is shown. The offering is at 20-40-60-80-100% on all or individual channels CH1-2-3-4 at the users discretion. Combinations can be made to have CH12 on Manual while CH34 is automatic or vice versa. If all manual operation is wanted, then simply select the channels desired until completed. The steps are shown below to achieve this. Press 7 and hold until the MSG>Key? is seen then release and press the desired power percent mode and channel as shown below and witness MSG> Done.

- **Summary of all manual modes of button sequences are below:**
Note: Examples below indicate pressing a 7 followed by the 0-9, #,* for various power and control combinations shown below.
 - 7-1 → Power CH1-2, 20%
 - 7-2 → Power CH1-2, 40%
 - 7-3 → Power CH1-2, 60%
 - 7-4 → Power CH1-2, 80%
 - 7-5 → Power CH3-4, 20%
 - 7-6 → Power CH3-4, 40%
 - 7-7 → Power CH3-4, 60%
 - 7-8 → Power CH3-4, 80%
 - 7-9 → Power CH1-2-3-4, 100%
 - 7-0 → Places System back in Automatic mode and removes Manual mode.

- 7-#-> **(RC-CDA-R only) Turns off Fan manually.** This operation only works if the unit is in manual mode by disabling auto mode for CH34 by using the '9' function below first before using this option. So, the keypad sequence "9 then 7 then #" will achieve this operation above. **(RS-CDA-R only) Turns on Rain Sensor.**
All other models. User Break Command. This cancels mode 7.
(SM-CDA-R only) Enables SQM Sensor.



Providing the Astronomical Community with Premier Products and Services

Astro-smart.com

Copyright © 2010-2049, All rights reserved

Jan 2020

- **7-*-> (RC-CDA-R only) Turns on Fan manually.** This operation only works if the unit is in manual mode by disabling auto mode for CH34 by using the '9' function below first before using this option. So, the keypad sequence "9 then 7 then *" will achieve this operation above. **(SM-CDA-R only) Disables SQM Sensor.**
(RS-CDA-R only) Adjust Rain Voltage Threshold

Note: Example. Pressing 7-1 gives CH1-2 at 20%, Pressing 7-7 now gives CH3-4 at 60%. The system will show all channels now in manual mode.

Note: Example. Pressing 7-1 gives CH3-4 at 20% with CH1-2 in auto mode.

- **'8' Enter:** on WEBGUI to enter **CDA-R FAMILY controller** pro with all 4 Channels activated CH 1-2-3-4 in Auto Mode by default where the user has both DTS sensors for CH 1-2 and CH 3-4. Manual mode is still available for all channels.
- **'9' Enter:** on WEBGUI to enter **CDA-R FAMILY controller** pro with only 2 Channels CH 1-2 activated in Auto Mode or the user only has one DTS sensor for CH-1-2. This allows CH 3-4 open for manual power control. CH-1-2 has option of auto or manual mode control. CH-3-4 can only be in manual operation in this mode with this selection and assuming no DTS sensor attached to CH 3-4.
- **'#' Enter:** For all models on WEBGUI will perform recalibration of humidity Offset value. For example, a '#' followed by add('5') or subtract('6') followed by a number '0-9' re-calibrates the humidity sensor in Flash non-volatile memory stored for future sessions. This has been done at factory.
- **'*' Enter:** For all models on WEBGUI will perform recalibration of Cutoff Voltage Offset value. For example a "*" followed by add('5') or subtract('6') followed by a number '0-9' re-calibrates the cutoff voltage threshold in Flash non-volatile memory stored for future sessions. This has been done at factory.
- **'o' Enter:** on WEBGUI for all systems will perform a soft reset.

Examples of using Modes with multi key entries from Keypad interface:

Notation Definitions: 7-(W2)-5 means Press 7, then wait 2 secs then press 5.

CDA-R Family Examples:

- **7-(W2)-5 → Places CH 3-4 in manual power mode 20%**



Providing the Astronomical Community with Premier Products and Services

Astro-smart.com

Copyright © 2010-2049, All rights reserved

Jan 2020

- 7-(W2)-1-(W2)-7-(W2)-6 → CH 1-2 20% and CH 3-4 40% manual power.
- 5-(W2)-*-(W2)-5 → Adjust Cutoff Voltage Sensitivity by +5.
- 6-(W2)-*-(W2)-5 → Adjust Cutoff Voltage Sensitivity by -6.
- 6-(W2)-*-(W2)-5-(W2)-# → Adjust Cutoff Voltage Sensitivity by -16.
- 5-(W2)-#-(W2)-5 → Adjust Humidity offset by +5.

RC-CDA-R Examples:

- 9-(W2)-7-(W2)-* → Places CH 3-4 in manual mode and Turns on Fan.
- 9-(W2)-7-(W2)-# → Places CH 3-4 in manual mode and Turns off Fan.

Note: RC-CDA-R will turn fan on with heat off and fan off with heat applied as needed in Auto mode for proper primary mirror dew abatement. The example above is if manual control of fan is desired.

RS-CDA-R Examples:

- 7-(W2)-# → Enables Rain Sensor
- 5-(W2)-7-(W2)-*-(W2)-5 → Adjusts Rain Sensor Sensitivity Voltage by +5.
- 6-(W2)-7-(W2)-*-(W2)-5 → Adjusts Rain Sensor Sensitivity Voltage by -5.

SM-CDA-R Examples:

- 7-(W2)-# → Enable SQM Sensor
- 7-(W2)-5 → Places CH 3-4 in manual power mode 20%

OC-RS-CDA-R Examples:

- 7-(W2)-7-(W2)-#- → Enables Rain Sensor
- 7-(W2)-# → Manual Toggle of Relay Control
- 7-(W2)-5 → Places CH 3-4 in manual power mode 20%

Note: “The following sections below describe CDA-R Family PC software interface to monitor and control your CDA-R Family as the information below mimics what is seen on your computer application.



Providing the Astronomical Community with Premier Products and Services

Astro-smart.com

Copyright © 2010-2049, All rights reserved

Jan 2020

K. Default Operation (Automated Dew Control)

By default operation, the **CDA-R FAMILY controller** is a automated dew heater that samples its surroundings and takes the appropriate actions, so you don't have to. So, lets look at a few scenarios, the unit may encounter!

1. Case 1. (Emergency Heat required because optic surfaces are colder than the surrounding environment!)

- **User Keypad Input Actions:** None! **CDA-R FAMILY controller** in Automatic Mode of Operation.
- Read Section L and M for more information.

CDA-R FAMILY controller Conditions And Actions:

- (Automatic Mode: Optic temperatures < Ambient temperatures by 10 degs or more)** Optics very cold and need immediate warm up. (ie, T12 by 10 degrees F or more).
 - Depending on the surrounding humidity, the dew point will be calculated and may be reached, in which case, the user will be notified that conditions for dew are present but the system will respond by abating by applying moisture heat control on the optics.*
 - 1KHz Alarm On Warning Heard.* This tells the user Dew may form with high probability and the system can control it automatically or by the user as well.
 - Power to Dew Straps.* (Optic temperatures < Ambient temperatures.)
In this case the optic differential channel will have a P12 power on display shown as PWM % during operation and heat strap output by touch. In this case t the corrector optics are 10 deg F less than the surrounding ambient temperature. This forces the system to apply heat to the optics as shown at a 100% PWM heat rate.

The screenshot displays the control interface for the CDA-R FAMILY controller, divided into two main sections: 'CDAP Input States' and 'CDAP Output Power // CDAP PRO Status'.

CDAP Input States:

TChannel12	63	degF	10	degC	1	
TChannel34	78	degF	25	degC	0	
Amb Temp	78	degF	25	degC	0	
Dew Point	61	degF	16	deg C	FLASH	New
Rel Humidity	38	%			Offset	Offset
Desired Humidity Offset					Humid	Cutoff_Offset
					Offset	Rain_Offset

CDAP Output Power // CDAP PRO Status:

P12	100	%	Auto Mode!	0	Power Curve Agressiveness	
P34	0	%	Auto Mode!		Current Power Bias Point	
Port Open! Real Time Mode Active!					-15	(AHTS - DTS12) degs
					0	(AHTS - DTS34) degs

Help Selecting Power Curve (Hoover Mouse Over Button!)



Providing the Astronomical Community with Premier Products and Services

Astro-smart.com

Copyright © 2010-2049, All rights reserved

Jan 2020

2. Case 2. (Normal Automated Dew Control, CPU PWM Controlled Heat)

- **User Keypad Input Actions:** None! **CDA-R FAMILY controller** in Automatic Mode of Operation.
- Read Section L and M for more information.

CDA-R FAMILY controller Conditions And Actions:

- i. **Automatic Mode: (Optic temperatures < Ambient temperatures by 5 degs or less CH 1-2 Only.)**
 - a. *Depending on the surrounding humidity, the dew point will be calculated and may be reached, in which case, the user will be notified that conditions for dew are present but the system will respond by abating the issue by applying moisture heat control on the optics.*
 - b. *No alarm is heard unless dewpoint is approaching. No alarm heard as optics are approaching ambient temperatures.*
 - c. *Power to Dew Straps. (Optic temperatures < Ambient temperatures.)*
 In this case the optic differential channel will have a P12 power on display shown as PWM % during operation and heat strap output by touch. In this case the corrector optics are 1 deg F less than the surrounding ambient temperature. This forces the system to apply heat to the optics as shown at a 20% PWM heat rate shown on P12 temperature duty rate. Note, since TC34 is 1 deg above Amb temp, there is no need for heat as shown with P34 at 0 % PWM. These channels have stabilized.

CDAP Input States						CDAP Output Power // CDAP PRO Status					
TChannel 12	78	degF	26	degC	1	P12	20	%	Auto Mode!	0	Power Curve Agressiveness
TChannel 34	79	degF	25	degC	0	P34	0	%	Auto Mode!		Current Power Bias Point
Amb Temp	79	degF	25	degC	0					-1	Desired Power Bias Point
Dew Point	61	degF	16	deg C	FLASH					0	(AHTS - DTS12) degs
Rel Humidity	38	%			Humid Offset						(AHTS - DTS34) degs
Desired Humidity Offset					New Offset						
					Cutoff_Offset						
					Rain_Offset						

Port Open!
Real Time Mode Active!

Help Selecting Power Curve (Hoover Mouse Over Button!)



Providing the Astronomical Community with Premier Products and Services

Astro-smart.com

Copyright © 2010-2049, All rights reserved

Jan 2020

3. Case 3. (Normal Automated Dew Control, CPU PWM Controlled Heat)

- **Equipment:** DTS12 and 1 Dew strap plugged into CH1 for main telescope optics. DTS34 input plugged in and CH3 and CH4 outputs being used.
- **User Keypad Input Actions:** None. **CDA-R FAMILY controller** in Automatic Mode of Operation.
- Read Section L and M for more information.

CDA-R FAMILY controller Conditions And Actions:

- i. **Automatic Mode: (Optic temperatures < Ambient temperatures by 5 degs or less on Ch12 and Ch34)**
 - a. Depending on the surrounding humidity, the dew point will be calculated and may be reached, in which case, the user will be notified that conditions for dew are present but the system will respond by abating the issue by applying moisture heat control on the optics.
 - b. No alarm is heard unless dewpoint is approaching. No alarm heard as optics are approaching ambient temperatures.
 - c. *Power to Dew Straps.* (Optic temperatures < Ambient temperatures.)
 In this case the optic differential channel will have a P12 power on display shown as PWM % during operation and heat strap output by touch. In this case corrector optics are 4 deg F less than the surrounding ambient temperature for CH 3-4. This forces the system to apply heat to the optics as shown at a 20% PWM heat rate shown on P34 and P12 temperature duty rate. T12 and T34 were 1 degree below ambient making a 20% duty rate shown on P12 and P34. The dew point is calculated based on the ambient temperature and relative humidity captured by onboard sensors.

The screenshot displays the control interface for the CDA-R FAMILY controller, divided into two main sections: 'CDAP Input States' and 'CDAP Output Power // CDAP PRO Status'.

CDAP Input States:

TChannel12	78	degF	26	degC	1	
TChannel34	78	degF	26	degC	0	
Amb Temp	79	degF	25	degC	0	
Dew Point	61	degF	16	degC	FLASH	New Offset
Rel Humidity	38	%			Humid Offset	Cutoff_Offset
Desired Humidity Offset						Rain_Offset

CDAP Output Power // CDAP PRO Status:

P12	20	%	Auto Mode!	0	Power Curve Agressiveness
P34	20	%	Auto Mode!		Current Power Bias Point
				-1	Desired Power Bias Point
				-1	(AHTS - DTS12) degs
				-1	(AHTS - DTS34) degs

Port Open!
Real Time Mode Active!

Help Selecting Power Curve (Hover Mouse Over Button!)



Providing the Astronomical Community with Premier Products and Services

Astro-smart.com

Copyright © 2010-2049, All rights reserved

Jan 2020

4. Case 4. (Normal Automated Dew Control, Logging Operation)

- **Equipment:** DTS12 and 1 Dew strap plugged into CH1 for main telescope optics. DTS34 input plugged in and CH3 and CH4 outputs being used.
- **User Keypad Input Actions:** User presses GUI Log Saving Function to be off. **CDA-R FAMILY controller** in Automatic Mode of Operation.
- Read Section L and M for more information.

CDA-R FAMILY controller Conditions And Actions:

- Automatic Mode: (Optic temperatures < Ambient temperatures by 5 degs or less on Ch12 and Ch34)**
 - Default operation is to save in C:\CDAP_Pro_Data directory with dated sub directory folders to store excel formatted .csv data files and .png graphic plot files of recorded retrieved data from the CDAP_Pro family system.*
 - When the user press the Save on button on GUI it will turn red and read Save Off to suspend recording. This can be useful to save storage on hard drive or to suspend recording when data capture is not desired.*

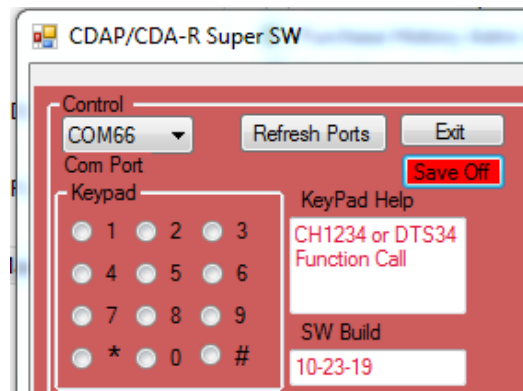
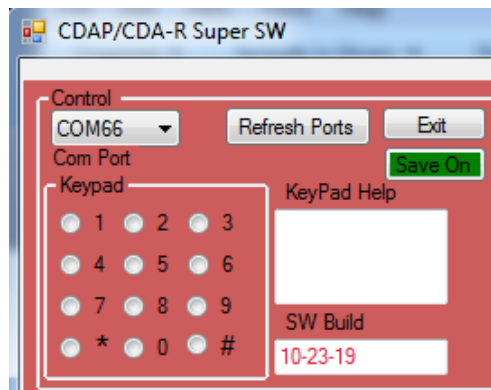



Providing the Astronomical Community with Premier Products and Services

Astro-smart.com

Copyright © 2010-2049, All rights reserved

Jan 2020

L. Manual Operation (Apply Heat As Desired On Channels)

1. Case 1. (Manual With Automatic Operation, Apply Heat As Desired CH-34)

- **Equipment:** In this case, DTS12 and DTS34 are plugged when in manual power mode as the user is controlling output power and bypassing **CDA-R FAMILY controller** sensor input. Temperature data will still be visible and note Man mode displayed. When the user returns to automatic mode, the sensors will regain usage by the system. DTS12 and P12 is in Automatic Mode independent of Ch-34 Manual activity.
- **User Keypad Input Actions: Example.** Pressing keypad button “7 “ followed by a “1” forces manual PWM heat to CH1-2 regardless of sensor input. User Mode of Operation forcing 20% PWM at the outputs. Note: Although temperature on DTS12 are in equilibrium with ambient temperature, the user can still turn on PWM to straps as shown.
- Note: CH3-4 still in Automatic Mode. The **CDA-R FAMILY controller** requires a complete circuit meaning the heat straps being plugged in to provide current drawl.
- Read Section L and M for more information.

Conditions:

- i. **(Manual Mode: User forces Desired Power %)**
 - a. User input on keypad and or computer WebGUI
 - b. In this case, Manual Operation can be achieved by user as well on either channels as shown below in standard operations section. Note: display readout for reference.

The screenshot displays the CDAP control interface with two main sections:

- CDAP Input States:**

TChannel 12	79	degF	26	degC	1	
TChannel 34	79	degF	25	degC	0	
Amb Temp	79	degF	25	degC	0	
Dew Point	61	degF	16	deg C	FLASH	New Offset
Rel Humidity	38	%			Humid Offset	Cutoff_Offset
Desired Humidity Offset						Rain_Offset
- CDAP Output Power // CDAP PRO Status:**

P12	20	%	Man Mode!	0	Power Curve Agressiveness	
P34	0	%	Auto Mode!		Current Power Bias Point	
Port Open! Real Time Mode Active!					0	Desired Power Bias Point
					0	(AHTS - DTS12) degs
					0	(AHTS - DTS34) degs
					Help: Selecting Power Curve (Hoover Mouse Over Button!)	



Providing the Astronomical Community with Premier Products and Services

Astro-smart.com

Copyright © 2010-2049, All rights reserved

Jan 2020

2. Case 2. (Manual Operation, Apply PWM Heat As Desired CH-1234)

- **Equipment:** DTS12 and DTS34 can be plugged in but they will be ignored when in manual power mode as the user is controlling output power and bypassing **CDA-R FAMILY controller** sensor input. When the user returns to automatic mode, the sensors will regain usage by the system is placed back in Automatic mode. Temperature data will still be visible and note Man mode displayed. When the user returns to automatic mode, the sensors will regain usage by the system.
- Note: Although temperature on DTS12 and DTS34 are in equilibrium with ambient temperature, the user can still turn on PWM to straps as shown.
- Note: CH1234 still in Manual Mode. The **CDA-R FAMILY controller** requires a complete circuit meaning the heat straps being plugged in to provide current drawl.
- **User Keypad Input Actions: Example. Case 1 and 2 above**
- Read Section L and M for more information for this option.

Conditions:

- i. **(Manual Mode: User forces Desired Power %)**
 - a. User input on keypad and or computer WebGUI as described in Section L,M.
 - b. In this case, Manual Operation can be achieved by user as well on either channel as shown in other cases below. Note: display readout for reference .

The screenshot displays the CDAP control interface, divided into two main sections: 'CDAP Input States' and 'CDAP Output Power // CDAP PRO Status'.

CDAP Input States:

TChannel 12	79 degF	26 degC	1	
TChannel 34	79 degF	25 degC	0	
Amb Temp	79 degF	25 degC	0	
Dew Point	61 degF	16 deg C	FLASH Offset	New Offset
Rel Humidity	38 %		Humid Offset	Cutoff_Offset
Desired Humidity Offset				Rain_Offset

CDAP Output Power // CDAP PRO Status:

P12	20 %	Man Mode!	0	Power Curve Agressiveness	
P34	20 %	Man Mode!	0	Current Power Bias Point	
Port Open!				0	Desired Power Bias Point
Real Time Mode Active!				0	(AHTS - DTS12) degs
				0	(AHTS - DTS34) degs

A button at the bottom right reads: **Help Selecting Power Curve (Hoover Mouse Over Button!)**



Providing the Astronomical Community with Premier Products and Services

Astro-smart.com

Copyright © 2010-2049, All rights reserved

Jan 2020

3. Case 3. (Return to Automatic Operation From Manual CH-1234)

- **Equipment:** DTS12 and DTS34 can be plugged in and operating in manual power mode as the user is controlling output power and bypassing **CDA-R FAMILY controller** sensor input. When the user returns to automatic mode, the sensors will regain usage by the system.
- **User Keypad Input Actions: User Presses “*” key which is a system reset which places unit back in Automatic mode.**
- Read Section L and M for more information for this option.

Conditions:

i. (Return to Automatic Operation From Manual CH-1234)

- User input on keypad and or computer WebGUI as described in Section L,M.
- In this case, Manual Operation can be achieved by user as well on either channel as shown in other cases below. Note: display readout for reference .

The screenshot displays the CDAP control interface, divided into two main sections: 'CDAP Input States' and 'CDAP Output Power // CDAP PRO Status'.

CDAP Input States:

TChannel 12	78 degF	26 degC	1	
TChannel 34	79 degF	25 degC	0	
Amb Temp	79 degF	25 degC	0	
Dew Point	61 degF	16 deg C	FLASH Offset	New Offset
Rel Humidity	38 %		Humid Offset	Cutoff_Offset
Desired Humidity Offset				Rain_Offset

CDAP Output Power // CDAP PRO Status:

P12	20 %	Auto Model!	0	Power Curve Agressiveness
P34	0 %	Auto Model!		Current Power Bias Point
				Desired Power Bias Point
				-1 (AHTS - DTS12) degs
				0 (AHTS - DTS34) degs

Alerts: Port Open! Real Time Mode Active!

Help: Selecting Power Curve (Hoover Mouse Over Button!)



Providing the Astronomical Community with Premier Products and Services

Astro-smart.com

Copyright © 2010-2049, All rights reserved

Jan 2020

4. Case 4. (Manual Dew Control, Logging Operation)

- **Equipment:** DTS12 and 1 Dew strap plugged into CH1 for main telescope optics. DTS34 input plugged in and CH3 and CH4 outputs being used.
- **User Keypad Input Actions:** User presses GUI Log Saving Function to be off. **CDA-R FAMILY controller** in Manual Mode of Operation.
- Read Section L and M for more information.

CDA-R FAMILY controller Conditions And Actions:

i. Manual Mode:

- Default operation is to save in C:\CDAP_Pro_Data directory with dated sub directory folders to store excel formatted .csv data files and .png graphic plot files of recorded retrieved data from the CDAP_Pro family system.*
- When the user press the Save on button on GUI it will turn red and read Save Off to suspend recording. This can be useful to save storage on hard drive or to suspend recording when data capture is not desired.*

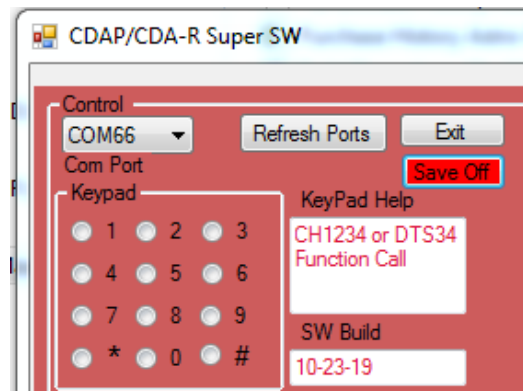
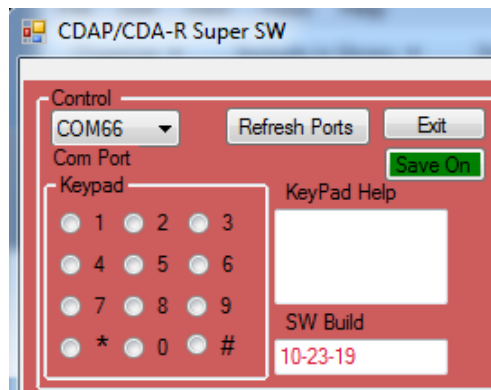



Providing the Astronomical Community with Premier Products and Services

Astro-smart.com

Copyright © 2010-2049, All rights reserved

Jan 2020

M. External Temperature Sensor Hints:

Install DTS Sensors at each location navigating under the dew straps. Try to attach to an area where no heating element is in contact with the sensor . You want to monitor optic temperature, not the heating element. For best results, mount the ambient temperature sensor (ATHS) on the optical tube with supplied Velcro while the optic Sensors DTS12/34 on the optical surfaces or inside the optical tube. See **Error! Reference source not found.** below



If no other option is available, route the sensors cables along with the dew strap cables underneath the fabric portion where no heating element resides. A convenient way to do this is to braid the two cables together, Figure below.



Providing the Astronomical Community with Premier Products and Services

Astro-smart.com

Copyright © 2010-2049, All rights reserved

Jan 2020

If you have two Sensors route one with the dew strap that is used for your telescope's front corrector. Route the second Sensor cable along with either the dew strap that is used for your eyepieces or your finderscope.



Route Sensor cable with Dew Strap cable



Providing the Astronomical Community with
Premier Products and Services

Astro-smart.com

Copyright © 2010-2049, All rights reserved

Jan 2020

N. Accessories

Optional Accessories:

Sensors:



Optional remote sensors for your **RC-CDA-R** or **CDA-R** are available ([2RSCDDDH-D](#)) to operate differential mode dew removal. One sensor is needed to operate Channels 1 and 2 output and a second sensor is required to operate Channels 3 and 4. These Remote Sensors allows you to control the heating of separate optical elements. For instance, one remote sensor would be placed with

your heater at the corrector and a second sensor could be placed on your finder scope objective lens or eyepiece or use two sensors on one large objective with two heater straps control. In these setups, each pair of heaters are controlled by their respective sensor while the supplied ambient temp sensor which comes with standard **RC-CDA-R** or **CDA-R** purchase can be placed on the main optical tube objective for ambient sensor collection. Using these sensors in this configuration allows greater dew control for the user. These items can be purchased at the same time as you purchase your **Computerized Dew Annihilator** (Model -**RC-CDA-R** or **CDA-R**) or at a later time.



Optional Professional remote sensors are available ([3RSCDDDH-D](#)) to operate differential mode dew removal that are suitable for higher accuracy and faster response in all environments . One sensor is needed to operate Channels 1 and 2 output and a second sensor is required to operate Channels 3 and 4. These Remote Sensors allows you to control the heating of separate optical elements. For instance, one remote sensor would be placed with your heater

at the corrector and a second sensor could be placed on your finder scope objective lens or



Providing the Astronomical Community with Premier Products and Services

Astro-smart.com

Copyright © 2010-2049, All rights reserved

Jan 2020

eyepiece or use two sensors on one large objective with two heater straps control. In these setups, each pair of heaters are controlled by their respective sensor while the supplied ambient temp sensor which comes with standard **RC-CDA-R or CDA-R** purchase can be placed on the main optical tube objective for ambient sensor collection. Using these sensors in this configuration allows greater dew control for the user. These items can be purchased at the same time as you purchase your **Computerized Dew Annihilator Pro** (Model -**RC-CDA-R or CDA-R**) or at a later time.



Optional accessory that Astro-Smart offers is the rain sensor ([4RAINSENSOR](#)). For use with SM-RS-CDA-R or any Astro-Smart Model with custom build option. That is correct. I can add this sensor to all variants of the CDAP-R model as a custom build option to new or preowned models. Goto the purchase page for this option. This sensor informs the user of rain fall when observing in standalone or remotely and gives the user

safety option decision making capability for the correct time to open and closing the observatory.



Optional accessory that Astro-Smart offers is the SQM(Sky Quality Meter) Standard sensor ([4SQMS](#)). For use with SM-CDA-R or any Astro-Smart Model with custom build option. That is correct. I can add this sensor to all variants of the CDA-R model as a custom build option to new or preowned models. Goto the purchase page for this option. This sensor informs the user of the quality of the sky conditions

for imaging, visual or technical work communicating with the user GUI interface which gives the user immediate feedback on cloud and sky conditions letting the user know if imaging, visual, technical work or a poor night for setting up your telescope. The SQM standard sensor provides dual graphing of MPSAS(Magnitude per square arc second) and NELM(Naked Eye Limiting Magnitude. See the video for this new amazing tool.



Providing the Astronomical Community with Premier Products and Services

Astro-smart.com

Copyright © 2010-2049, All rights reserved

Jan 2020

Mounting and Power:



Another convenient accessory that Astro-Smart offers is a right angle mounting brackets ([RAMB-DM](#)). This allows your **CDA-R Product Family** controller to be mounted securely on a variety of surfaces.



Another convenient accessory that Astro-Smart offers is a right angle heater connector ([RAHC-DM](#)). This allows your heater to be connected to the **Computerized Dew Annihilator family** at a right angle. This may be convenient for you to alleviate any bending that you have of your heater connector and wire.



Another convenient accessory that Astro-Smart offers is the Y RCA heater connector ([YHC-DM](#)). This allows your heater to be connected to the **Computerized Dew Annihilator family** with more than one heat strap. This may be convenient for you if you want to distribute two heat straps evenly or you need 5 straps on a 4 port system.



Another convenient accessory for your **Computerized Dew Annihilator family** that Astro-Smart offers is Three versions of power supplies based on your dew heating needs choosing between 6, 8 or 10Amp // 12 VDC supplies ([PS12VXAMP-D](#)).



Providing the Astronomical Community with Premier Products and Services

Astro-smart.com

Copyright © 2010-2049, All rights reserved

Jan 2020

Communication Options:



Another convenient accessory add-on that Astro-Smart offers is the USB-3/2 7 Port Astro-Hub optional add on interface specifically designed for the **Computerized Dew Annihilator family controller**. For dedicated communication distances less than 50 feet with USB-3 equipment and 80 feet for USB-2 equipment to your computer. The Astro-Hub can be used with your **Computerized Dew Annihilator family** controller and other telescope equipment such as cameras, focusers, mount, etc to your computer or other backhaul interface (ie ethernet or wireless options)([USB-3/2-Astro-Hub](#)).



computer([ETHER-DM](#)).

http://astro-smart.com/index.php?p=1_51 Another convenient accessory that Astro-Smart offers is a Ethernet interface specifically designed for the **Computerized Dew Annihilator family**. You just plug the supplied RS-232-USB connector that comes with your **Computerized Dew Annihilator family** into the female USB to Ethernet converter. Now, plug in the desired length of Ethernet CAT-5 to your remote control computer location to the other CAT-5 termination and simply plug in the USB connector to your



Another convenient accessory add-on that Astro-Smart offers is the Serial to Serial Extender interface specifically designed for the **Computerized Dew Annihilator family**. For dedicated communication distances less than 500 feet to your computer, the RS232EXT option is right for you. You just plug the supplied Serial Cable into your your **Computerized Dew Annihilator family** controller Serial port and the other Serial port adapter end of the cable into your supplied serial to USB-A adapter that comes with your **Computerized Dew Annihilator family** controller computer or other backhaul interface to your computer(ie ethernet or wireless options)([SERIAL-EXT](#)).



Providing the Astronomical Community with Premier Products and Services

Astro-smart.com

Copyright © 2010-2049, All rights reserved

Jan 2020



Bluetooth Wireless (200 FT)

Another convenient accessory add-on that Astro-Smart offers is a RF Bluetooth Wireless interface specifically designed for the **Computerized Dew Annihilator family**. For dedicated wireless communication distances less than 200 feet to your computer, the embedded bluetooth upgrade option is right for you. You just connect with your bluetooth capable PC or use supplied bluetooth adapter and enjoy a Wireless connection that's wire free upto 200 feet of unit separation. This add on gives the user ability for simultaneous use of

supplied standard serial/USB port interface plus the addition of the Wireless Bluetooth port which can run two remote software applications at once if desired.



RF ISM Wireless (650 FT)

Another convenient accessory add-on that Astro-Smart offers is a RF Wireless interface specifically designed for the **Computerized Dew Annihilator Pro family**. For dedicated wireless communication distances less than 656 feet to your computer, the [\(RF200M-DM\)](#) option is right for you. You just plug the supplied RS-232-USB connector that comes with your **Computerized Dew Annihilator family** into the female RF-Wireless Adapter converter which is attached to your remote

Computer's USB port. Now, plug in the other RF Wireless interface unit to the RS-232 port of the **Computerized Dew Pro Annihilator family** and you now have a Wireless connection that supports a RF link wire free upto 656 feet of unit separation. [\(RF200M-DM\)](#).



Providing the Astronomical Community with Premier Products and Services

Astro-smart.com

Copyright © 2010-2049, All rights reserved

Jan 2020

Dew Straps:



Another product Astro-Smart offers is our Premium Dew Heater Straps. Astro-Smart is proud to announce the offering of our Premium Dew Controller straps that can be used with the Astro-Smart Dew Controller products and compatible with other vendor dew controllers with RCA jack input to control temperature of your telescope optics, cameras, camera lens, telescope eyepieces and sensitive electronics.

The materials used for these Premium Dew Straps include Industrial Velcro, High Quality Insulating Material to project heat toward the optics and away from the atmosphere, 5 foot power cord with male RCA connector and Power Conductor Current capable

of 10 Amps.

<http://astro-smart.com/index.php?p=1> 51



Providing the Astronomical Community with
Premier Products and Services

Astro-smart.com

Copyright © 2010-2049, All rights reserved

Jan 2020

O. Warranty, Policies, Copyright Notice:

Life Time Warranty

All products are guaranteed to the original purchaser to be free from defects in material and workmanship for the life of the product from the date of original purchase. Simply put, your once you buy a Astro-Smart product we make sure it works for as long as you keep the product for free upgrades of software and firmware for the product. Warranty coverage excludes normal wear and tear, or damage caused by improper installation, any modification, abuse, misuse, improper maintenance, and unauthorized repairs or modifications to the original product. Shipper is responsible for proper packaging, shipping and insurance on applicable upgrades or repair items. . Upon receipt of returned product, Astro-Smart will assess the item/s to determine if they comply with the conditions of our warranty. Astro-Smart is not responsible for damage caused by the freight carrier, i.e.: USPS, UPS, FED EX, etc., to our product. A claim to repair or replace the product must be initiated by the recipient. In no event shall Astro-Smart be liable for any claim for incidental or consequential damage arising out of or in connection, manufacture, delivery or use of any product offered on this website or by information received by US mail, E-mail, data files or fax.

Return Policy

Merchandise must be returned in new (mint) condition within 30 days of receipt for exchange/refund which may be subject to 20% restocking charge (Shipper is responsible for proper packaging, shipping, and insurance.). We must receive the returned merchandise within 30 days of the date you received it. All items must be in new (mint) condition and fully functional. Returned items cannot show evidence of use or wear, dirt, or blemishes of any kind. Merchandise must be returned in its original packaging and should include all supplied materials, instructions, original accessories, hardware, and any CD software disks provided. Software purchases via email or download since released are non-refundable. Astro-Smart is not responsible for lost or damaged packages. Return shipping costs are the responsibility of the customer. Any returned items must be in "as new" condition. We ask that you open and inspect your order upon receipt. No insurance or damage claims will be



Providing the Astronomical Community with
Premier Products and Services

Astro-smart.com

Copyright © 2010-2049, All rights reserved

Jan 2020

accepted more than 3 days after delivery. All customers MUST email Astro-Smart before returning products for warranty or repair to get an RMA# (Return Merchandise Authorization).

Copyright Notice

All Astro-Smart products are protected by U.S. and International Copyright laws. Unauthorized use, duplication, distribution or reproduction of any intellectual property including concepts, ideas or applications of these products are prohibited and are subject to International and U.S laws governing export and re-exporting owned by Astro-Smart - smart.com Copyright © 2010-2039, All rights reserved.